

# 截止阀系列

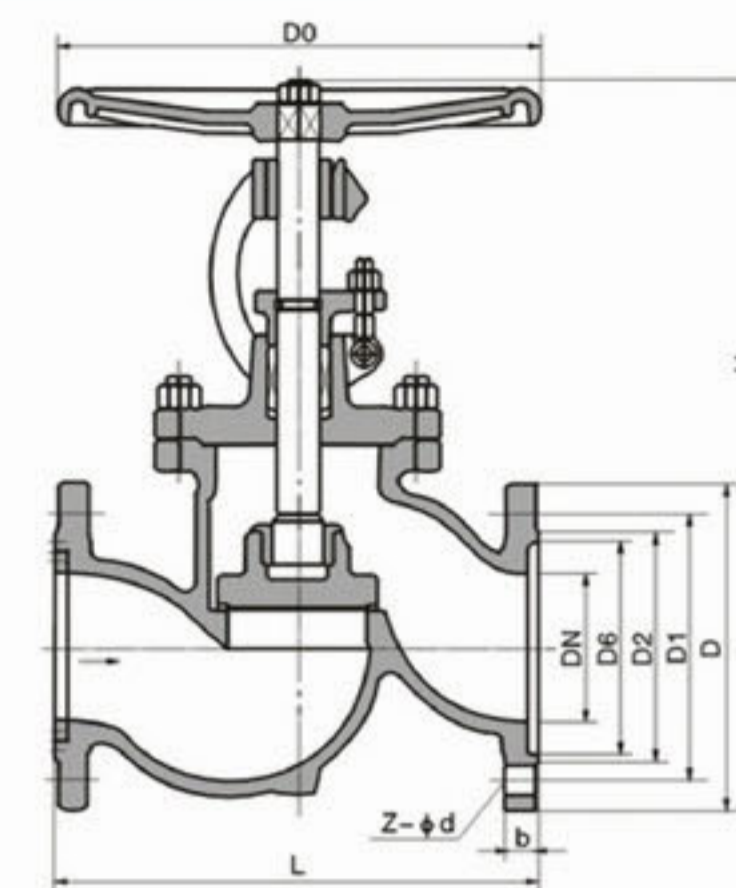

## 截止阀 Globe Valves



### 产品执行标准 Production enforce standard

产品规范 Product Specification	设计规范 Design Spec	结构长度 Face to Face	连接法兰 Flange End	试验与检验 Test Check	压力-温度 Pressure-Temp	产品标识 Marking	供货规范 Supply
	GB/T12235	GB/T12221	JB/T79	JB/T9092	GB/T9131	GB/T12220	JB/T7928

### 产品性能规范 Chief property and specification

#### 1、试验压力 Test pressure

公称压力 (Lb) Nominal Pressure	1.6	2.5	4.0	6.4	10.0	16.0
壳体强度试验 Shell strength test	2.4	3.8	6.0	9.6	15	24
上密封试验 Back seal test	1.8	2.8	4.4	7.0	11	18
密封试验 Seal test	1.8	2.8	4.4	7.0	11	18

#### 2、适用介质及适用温度 Applicable medium & Applicable temperature

产品类型 Product type	适用介质 Applicable medium	适用温度°C Applicable temperature
J41Y-C型 J941Y-C型	水、油品、蒸气 Water, oil, steam	≤425 ≤450
J41W-P型 J941W-P型	硝酸类 Nitric acid	≤200
J41W-R型	盐酸类 Hydrochloric acid	≤200
J41Y-I型 J941Y-I型	水、油品、蒸气 Water, oil, steam	≤550

### 主要零件材料 Material for main parts

产品名称 Product type	零件名称 Part name							
	阀体、阀盖 Body bonnet	阀杆 Stem	阀瓣 Sealing face	密封面 sealing face	阀杆螺母 Yoke nut	填料 Packig	紧固件 Fastener	手轮 Hand wheel
J41Y-C型 J941Y-C型	2.5WCB	铬不锈钢 Cr.Stainless steel	2Cr13 25	H: 不锈钢 Y: 钴基硬质合金 H: Stainless steel Y: Co-based carbide alloy steel	铝青铜 Al bronze	柔性石墨 Flexibile graphite	优质碳钢 High-grade carbon steel	可锻铸铁 Foraeable cast-iron
J41W-P型 J941W-P型	铬镍钛钢 Cr,Ni,Ti steel	铬镍钛钢 Cr,Ni,Ti steel	铬镍钛钢 Cr,Ni,Ti steel	铬镍钛钢 Cr,Ni,Ti steel	铝青铜 Al bronze	柔性石墨 Flexibile graphite	不锈钢 Stainless steel	可锻铸铁 Foraeable cast-iron
J41W-R型	铬镍钼钛钢 Cr,Ni,Mo,Ti steel	铬镍钼钛钢 Cr,Ni,Mo,Ti steel	铬镍钼钛钢 Cr,Ni,Mo,Ti steel	铬镍钼钛钢 Cr,Ni,Mo,Ti steel	铝青铜 Al bronze	柔性石墨 Flexibile graphite	不锈钢 Stainless steel	可锻铸铁 Foraeable cast-iron
J41Y-I型 J941Y-I型	铬钼钢 Cr,Mo steel	铬钼钢 Cr,Mo steel	合金钢 Alloy steel	钴基硬质合金 Co-based carbide alloy steel	铝青铜 Al bronze	柔性石墨 Flexibile graphite	合金钢 Alloy steel	可锻铸铁 Foraeable cast-iron



### 电动截止阀

Electric Globe valves J41W/Y-16P/R/I

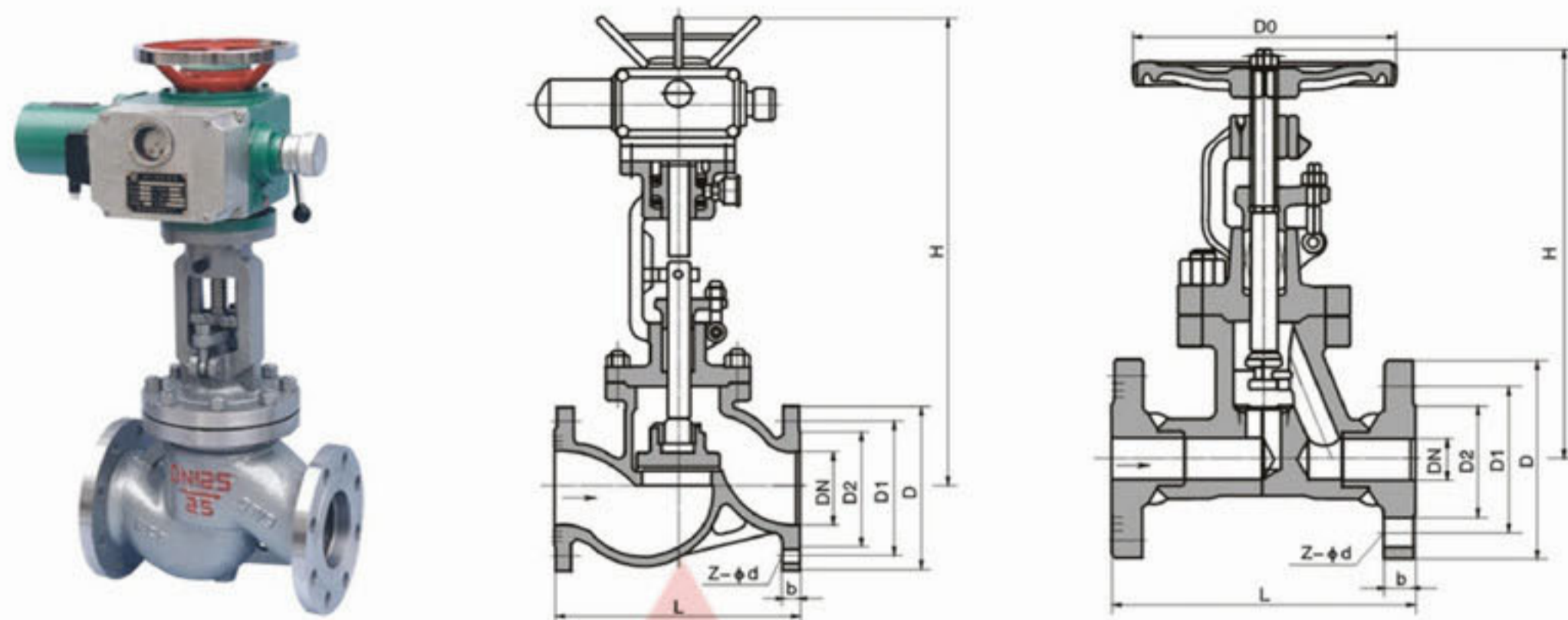

主要外形和连接尺寸 Main External and Connection Dimension

单位Unit:mm

公称通径 DN	主要外形尺寸和连接尺寸 (mm) Main external and connecting dimensions									WT(Kg)
	L	D	D1	D2	b	f	Z-d	H	D0	
J41Y <sup>H</sup> -16C J41W-16P J41W-16R J41Y-16I										
10	130	90	60	40	14	2	4-14	198	120	4.7
15	130	95	65	45	16	2	4-14	218	120	5.2
20	150	105	75	55	16	2	4-14	258	140	7.1
25	160	115	85	65	16	2	4-14	275	160	7.4
32	180	135	100	78	18	2	4-18	280	180	8.5
40	200	145	110	85	18	3	4-18	330	200	12.5
50	230	160	125	100	18	3	4-18	350	240	20
65	290	180	145	120	18	3	4-18	400	280	25
80	310	195	160	135	20	3	8-18	355	280	35
100	350	215	180	155	22	3	8-18	415	320	50
125	400	245	210	185	24	3	8-18	460	360	75
150	480	280	240	210	24	3	8-23	510	400	100
200	600	335	295	265	26	3	12-23	710	400	210
250	650	405	355	320	30	3	12-23	768	450	446
300	750	460	410	375	30	3	12-23	925	500	648

### 电动截止阀

Electric Globe valves J41W/H/Y-25-40P/R/I

主要外形和连接尺寸 Main External and Connection Dimension

公称通径 DN	主要外形尺寸和连接尺寸 (mm) Main external and connecting dimensions										电动装置 Electric device		WT(Kg)	
	L	D	D1	D2	b	f	Z-d	H手	H电	D0	手动 Hand	电动 Electric		
J41Y <sup>H</sup> -25 J41W-25P J41W-25R J41Y-25I J941Y <sup>H</sup> -25 J941W-25P J941W-25R J941Y-25II														
10	130	90	60	40	16	2	4-14	198	-	120	-	4.9	-	
15	130	95	65	45	16	2	4-14	218	-	120	-	5.4	-	
20	150	105	75	55	16	2	4-14	258	-	140	-	7	-	
25	160	115	85	65	16	2	4-14	275	-	160	-	7.4	-	
32	180	135	100	78	18	2	4-18	280	-	180	-	8.5	-	
40	200	145	110	85	18	3	4-18	330	-	200	-	12.5	-	
50	230	160	125	100	20	3	4-18	350	645	240	DZW101	16	50	
65	290	180	145	120	22	3	8-18	400	690	280	DZW101	25	62	
80	310	195	160	135	22	3	8-18	355	715	280	DZW151	30	67	
100	350	230	190	160	24	3	8-23	415	770	320	DZW20	34.5	73	
125	400	270	220	188	28	3	8-25	460	780	360	DZW30	89	127	
150	480	300	250	218	30	3	8-25	510	875	400	DZW45	98	215	
200	600	360	310	278	34	3	12-25	710	967	400	DZW60	180	322	
250	650	425	370	332	36	3	12-30	786	-	450	-	446	-	
300	750	485	430	390	40	4	12-30	925	-	500	-	654	-	

公称通径 DN	主要外形尺寸和连接尺寸 (mm) Main external and connecting dimensions											电动装置 Electric device		WT(Kg)	
	L	D	D1	D2	D6	b	f	f2	Z-d	H手	H电	D0	手动 Hand	电动 Electric	
J41Y <sup>H</sup> -40 J41W-40P J41W-40R J41Y-40I J941Y <sup>H</sup> -40 J941W-40P J941W-40R J941Y-40I															
10	130	90	60	40	35	16	2	4	4-14	198	-	120	-	4.9	-
15	130	95	65	45	40	16	2	4	4-14	233	-	120	-	5.4	-
20	150	105	75	55	51	16	2	4	4-14	275	-	140	-	7	-
25	160	115	85	65	58	16	2	4	4-14	285	-	160	-	8.8	-
32	180	135	100	78	66	18	2	4	4-18	302	-	180	-	11.8	-
40	200	145	110	85	76	18	3	4	4-18	355	-	200	-	16.5	-
50	230	160	125	100	88	20	3	4	4-18	373	645	240	DZW101	24	61
65	290	180	145	120	110	22	3	4	8-18	408	690	280	DZW101	33	75
80	310	195	160	135	121	22	3	4	8-18	436	715	320	DZW201	44	84
100	350	230	190	160	150	24	3	4.5	8-23	480	770	360	DZW301	60	101
125	400	270	220	188	176	28	3	4.5	8-25	558	782	400	DZW45	89	207
150	480	300	250	218	204	30	3	4.5	8-25	611	875	400	DZW60	98	226
200	600	375	320	282	260	38	3	4.5	12-30	720	1160	400	DZW901	190	339



### 电动截止阀

Electric Globe valves J41/941 W/Y-64~160/I

#### 主要外形和连接尺寸 Main External and Connection Dimension

公称 口径 DN	主要外形尺寸和连接尺寸 (mm) Main external and connecting dimensions												电动装置 Electric device		WT(Kg)	
	L	D	D1	D2	D6	b	f	f <sub>2</sub>	Z-d	H手	H电	D0	手动 Hand	电动 Electric		
J41 <sup>H</sup> -64 J941 <sup>H</sup> -64 J41Y-64I J941Y-64I																
10	170	100	70	50	35	18	2	4	4-14	198	-	120	-	5.7	-	
15	170	105	75	55	41	18	2	4	4-14	195	-	140	-	10	-	
20	190	125	90	68	51	20	2	4	4-18	228	-	160	-	13	-	
25	210	135	100	78	58	22	2	4	4-18	275	-	180	-	14.5	-	
32	230	150	110	82	66	24	2	4	4-23	325	-	200	-	19	-	
40	260	165	125	95	76	24	3	4	4-23	360	-	240	-	25	-	
50	300	175	135	105	88	26	3	4	8-23	410	710	280	DZW10	35	64	
65	340	200	160	130	110	28	3	4	8-23	450	750	320	DZW15	48	77	
80	380	210	170	140	121	30	3	4	8-23	485	785	360	DZW30	56	88	
100	430	250	200	168	150	32	3	4	8-25	537	837	400	DZW45	125	171	
125	500	295	240	202	176	26	3	4	8-30	631	-	400	-	131	-	
150	550	340	280	240	204	38	3	4	8-34	646	-	450	-	157	-	
200	650	405	345	300	260	44	3	4	12-34	813	-	500	-	283	-	
J41 <sup>H</sup> -100 J941 <sup>H</sup> -100 J41Y-100I J941Y-100I																
10	170	100	70	50	35	20	2	4	4-14	198	-	120	-	6	-	
15	170	105	75	55	40	20	2	4	4-14	202	-	140	-	11	-	
20	190	125	90	68	51	22	2	4	4-18	228	-	160	-	13.2	-	
25	210	135	100	78	58	24	2	4	4-18	250	-	180	-	14	-	
32	230	150	110	82	66	24	2	4	4-23	326	-	220	-	15	-	
40	260	165	125	95	76	26	3	4	4-23	359	-	240	-	29	-	
50	300	195	145	112	88	28	3	4	4-25	414	710	280	DZW15	49	82	
65	340	220	170	138	110	32	3	4	8-25	434	750	320	DZW20I	65	104	
80	380	230	180	148	121	34	3	4	8-25	547	785	400	DZW30	95	138	
100	430	265	210	172	150	38	3	4.5	8-30	621	837	450	DZW45	115	243	
125	500	310	250	210	176	42	3	4.5	8-34	732	-	450	-	149	-	
150	550	350	290	250	204	46	3	4.5	12-34	840	-	500	-	310	-	
200	650	430	360	312	260	54	3	4.5	12-41	925	-	550	-	590	-	
J41 <sup>H</sup> -160																
15	170	110	75	52	40	24	2	4	4-18	148	-	140	-	12.2	-	
20	190	130	90	65	51	26	2	4	4-23	156	-	160	-	15	-	
25	210	140	100	72	58	28	2	4	4-23	125	-	180	-	17	-	
32	230	165	115	85	66	30	2	4	4-25	200	-	200	-	21.4	-	
40	260	175	125	92	76	32	3	4	4-27	231	-	240	-	32	-	
50	300	215	165	132	88	36	3	4	8-25	262	-	250	-	52	-	
65	340	245	190	152	110	44	3	4	8-30	303	-	320	-	69	-	
80	380	260	205	168	121	46	3	4	8-30	341	-	400	-	98	-	
100	430	300	240	200	150	48	3	4.5	8-34	485	-	450	-	119	-	

### 美标截止阀门

API Globe valves

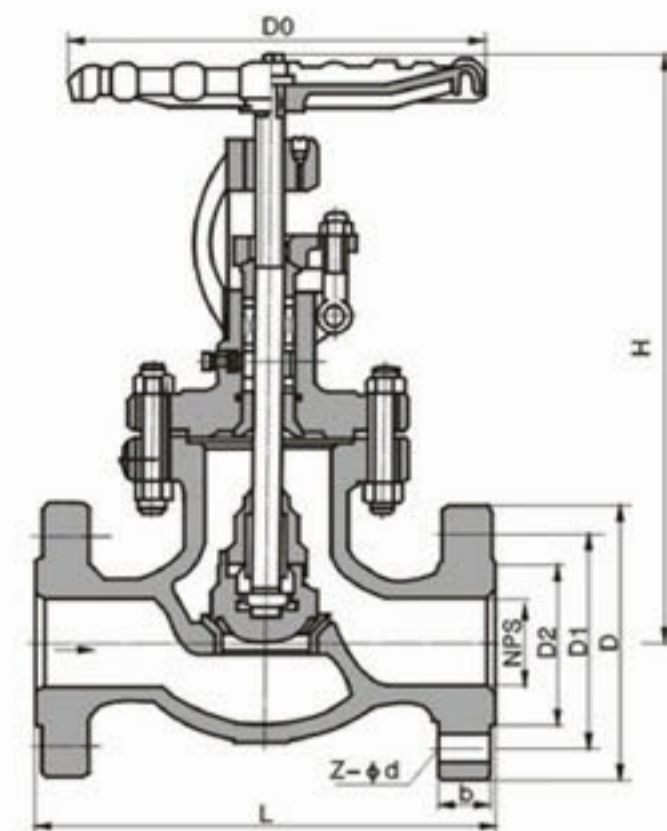

#### 产品执行标准 Production enforce standard

设计与制造 Desing And Manufacture	结构长度 Face to face/ End to end	法兰尺寸 Flang Dimension	对焊连接尺寸 Butt welding dimension	压力~温度 Pressure Temperature Lating	试验~检验 Inspection and test
ANSI B16.34、BS1873	ANSI B16.10	ANSI B16.5	ANSI B16.25	ANSI B16.34	API 598

#### 产品性能规范 Chief property and specification

公称压力(Lb) Nominal Pressore	强度试验Shell test		水密封试验Waetr seal test		气密封试验Air seal test	
	Mpa	Lbf/in <sup>2</sup>	Mpa	Lbf/in <sup>2</sup>	Mpa	Lbf/in <sup>2</sup>
150	3.1	450	2.2	315	0.5~0.7	60~100
300	7.8	1125	5.6	815		
600	15.3	2225	11.2	1630		
900	23.1	3350	16.8	2440		
1500	38.4	5575	28.1	4080		
2500	64.6	9367	47.4	6873		

#### 主要零件材料 Material for main parts

体、盖、瓣 Body Cover disc	阀杆 Stem	密封面 Sealing Face	垫片(环) Sealing shim	填料 Packing	工作温度(°C) Working temperature	适用介质 Suitable medium
WCB	2Cr13	13Cr STL 本体材料 With bodymater rial PTFE 尼龙 Nylon	增强柔性石墨 13Cr/柔性石墨 Enhanced Flexible graphite 1Cr13/Flexible graphite SFB-2 08软钢 08Soft steel F304 F316 F304L F316L	柔性石墨 增强柔性石墨 Flesible graphite enhanced flexible graphite SFB/260 SFP/260 PTFE	≤425	水、蒸气、油品 Water Steam Petroleum Products
WC1	38CrMoAl 25Cr2Mov				≤450	
WC6					≤540	
WC9					≤570	
C5 C12					≤540	
CF8	F304				≤600	
CF3	F316					
CF8M	F304L					
CF3M	F316L					



### 美标截止阀门

API Globe valves Class-150Lb

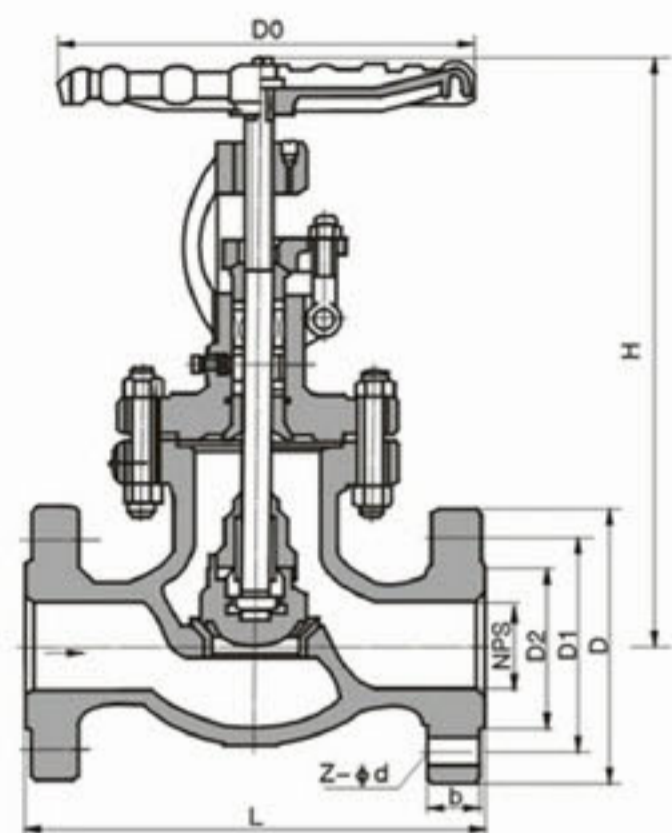

主要外形和连接尺寸 Main External and Connection Dimension

磅级 Class	规格 Size	L	D	D1	D2	b	n-φd	W	H	WT (Kg)	
150LB	1/2"	mm	108	90	60.5	35	12	4-15	125	169	3.8
		in	4.25	3.5	2.38	1.38	0.47	4-0.59	4.92	6.65	
	3/4"	mm	117	98	70	43	12	4-15	125	180	4.2
		in	4.61	3.86	2.76	1.69	0.47	4-0.59	4.92	7.08	
	1"	mm	127	108	79.5	51	12	4-15	125	190	8
		in	5	4.25	3.13	2	0.47	4-0.59	4.92	7.48	
	1 1/2"	mm	165	127	98.5	73	14.3	4-16	180	347	13
		in	6.5	5	3.88	2.87	0.56	4-0.62	7.09	13.66	
	2"	mm	203	152	120.5	92	15.9	4-19	180	356	21
		in	8.00	6.00	4.75	3.62	0.625	4-0.75	7.09	14	
	2 1/2"	mm	216	178	139.5	105	17.5	4-19	240	381	30
		in	8.5	7	5.50	4.12	0.69	4-0.75	9.45	15.00	
	3"	mm	241	190	152.4	127	19.1	4-19	280	13	41
		in	9.5	7.50	6	5	0.75	4-0.75	11.02	16.25	
	4"	mm	292	229	190.5	157	24	8-19	280	500	64
		in	11.50	9.00	7.5	6.19	0.94	8-0.75	11.02	19.68	
6"	mm	406	279	241.5	216	25.4	8-22	360	656	113	
	in	16	11.0	9.50	8.5	1.00	8-0.88	14.17	22.25		
8"	mm	495	343	298.5	270	29	8-22	450	660	190	
	in	19.5	13.5	11.75	10.62	1.12	8-0.88	17.75	26.00		

### 美标截止阀门

API Globe valves Class-300Lb-600Lb

主要外形和连接尺寸 Main External and Connection Dimension

磅级 Class	规格 Size	L	D	D1	D2	b	n-φd	W	H	WT (Kg)	
300Lb	1/2"	mm	152	95	66.5	35	15	4-15	125	190	4.5
		in	5.98	3.74	2.62	1.38	0.95	4-0.59	4.92	7.84	
	3/4"	mm	178	117	82.5	43	16	4-19	125	212	8
		in	7	4.61	3.25	1.69	0.62	4-0.75	4.92	8.35	
	1"	mm	203	124	89	51	18	4-19	160	231	10
		in	8	4.9	3.50	2	0.71	4-0.75	6.2	9.1	
	1 1/2"	mm	229	156	114.5	73	20.7	4-22	200	391	18.5
		in	9	6.12	4.51	2.87	0.81	4-0.87	8	15.43	
	2"	mm	267	165	127	92	22	8-19	200	406	37
		in	105	6.5	5	3.62	0.88	8-0.75	7.87	16.00	
	2 1/2"	mm	292	190	149	105	25	8-22	240	457	50
		in	11.5	7.50	5.88	4.12	1.00	8-0.88	9.45	18.00	
	3"	mm	318	210	168.5	127	29	8-22	280	470	61
		in	12.50	8.25	6.62	5	1.12	8-0.88	11.02	18.50	
	4"	mm	356	245	200	157	32	8-22	320	590	99
		in	14.00	10.00	7.88	6.19	1.25	8-0.88	12.60	23.23	
6"	mm	444	318	270	216	37	12-22	500	711	176	
	in	17.50	12.50	10.62	8.5	1.44	12-0.88	19.68	28.00		
8"	mm	559	381	330	270	41	12-25	500	750	333	
	in	22.0	15	13.00	10.62	1.62	12-100	19.68	29.50		

主要外形和连接尺寸 Main External and Connection Dimension

磅级 Class	规格 Size	L	D	D1	D2	b	n-φd	W	H	WT (Kg)	
600Lb	1/2"	mm	165	95	66.5	35	15	4-15	160	285	6
		in	6.5	3.74	2.62	1.38	0.59	4-0.59	6.2	11.22	
	3/4"	mm	190	117.5	82.5	43	16	4-19	160	285	9
		in	7.48	4.61	3.25	1.69	0.62	4-0.75	6.2	11.22	
	1"	mm	216	124	89	51	18	4-19	160	313	12
		in	8.5	4.9	3.5	2	0.71	4-0.75	6.2	12.32	
	1 1/2"	mm	241	156	114.5	73	23	4-22	240	365	22
		in	9.5	6.12	4.51	2.87	0.91	4-0.88	9.45	14.17	
	2"	mm	292	165	127	92	25	8-19	240	444	39
		in	11.50	6.50	5.00	3.62	1.00	8-0.75	9.45	17.50	
	2 1/2"	mm	330	190	149	105	29	8-22	240	483	50
		in	13	7.50	5.88	4.12	1.12	8-0.08	9.45	19	
	3"	mm	356	210	168	127	32	8-22	280	533	68
		in	14.00	8.25	6.62	5	1.25	8-0.88	11.02	21	
	4"	mm	406	273	216	157	38.1	8-25	360	622	120
		in	16.00	10.75	8.5	6.19	1.5	8-1.00	14.17	24.50	
6"	mm	459	356	292	216	47.7	12-29	500	800	220	
	in	19.50	14	11.5	8.5	1.88	12-1.14	19.68	31.50		
8"	mm	597	419	349	270	55.6	12-32	550	927	450	
	in	23.50	16.5	13.75	10.62	2.19	12-1.25	21.65	36.50		



波纹管截止阀  
Bellows Globe valves

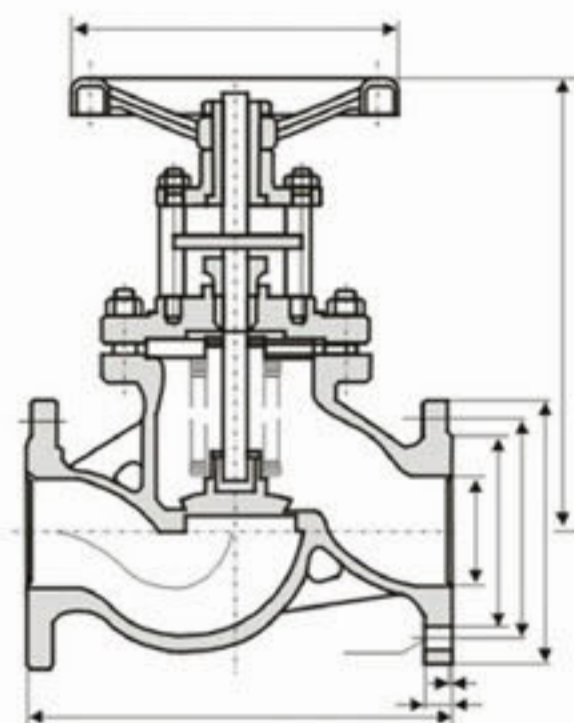
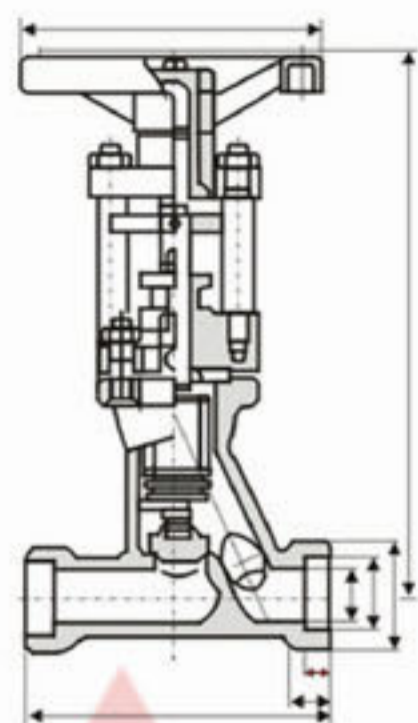

主要外形和连接尺寸 Main External and Connection Dimension(WJ61)

单位Unit:mm

公称口径 DN	L	D	D1	L1	L2	H	Do	WT(kg)
WJ61H-16C WJ61H-25C WJ61H-40C WJ61H-16C WJ61H-25P WJ61H-40P								
15	110	34	22.5	10	18	214	22.5	1.9
20	130	40	28.5	11	18	242	28.5	2.3
25	140	48	34.5	12	20	245	34.5	3.4
32	160	56	43	14	22	296	43	5.2
40	180	64	49	15	25	337	49	7.3
50	230	85	61	18	28	342	61	10

主要外形和连接尺寸 Main External and Connection Dimension(WJ41型)

单位Unit:mm

公称口径 DN	L	D	D1	D2	b	f	Z-φd	H	Do	WT(kg)
WJ41H-16C WJ41W-16P										
15	130	95	65	47	14	2	4-13.5	202	120	5
20	150	105	75	58	14	2	4-13.5	231	140	7
25	160	115	85	68	14	2	4-13.5	231	140	9
32	180	140	100	78	16	2	4-17.5	286	160	12
40	200	150	110	88	16	3	4-17.5	317	200	16
50	230	165	125	102	16	3	4-17.5	317	200	19
65	290	185	145	122	18	3	8-17.5	331	240	23
80	310	200	160	123	20	3	8-17.5	402	240	30
100	350	220	180	158	20	3	8-17.5	416	320	42
125	400	250	210	184	22	3	8-17.5	467	360	63
150	480	285	240	212	24	3	8-22	525	360	90
200	600	340	295	268	26	3	12-22	611	500	150
WJ41H-25 WJ41W-25P										
15	130	95	65	47	16	2	4-13.5	202	120	5
20	150	105	75	58	16	2	4-13.5	231	160	7
25	160	115	85	68	16	2	4-13.5	231	160	9
32	180	140	100	78	18	2	4-17.5	286	160	12
40	200	150	110	88	18	3	4-17.5	317	200	19
50	230	165	125	102	20	3	4-17.5	317	200	24
65	290	185	145	122	22	3	8-17.5	331	280	33
80	310	200	160	133	22	3	8-17.5	402	280	44
100	350	235	190	158	24	3	8-22	416	320	60
125	400	270	220	184	28	3	8-26	467	360	72
150	480	300	250	212	30	3	8-26	525	360	98
200	600	360	310	278	30	3	12-27	611	500	169
WJ41H-40 WJ41W-40P										
15	130	95	65	47	16	2	4-13.5	202	120	5
20	150	105	75	58	16	2	4-13.5	228	160	7
25	160	115	85	68	16	2	4-13.5	228	160	9
32	180	140	100	78	18	2	4-17.5	274	160	12
40	200	150	110	88	20	3	4-17.5	345	200	16
50	230	165	125	102	22	3	4-17.5	396	200	23
65	290	185	145	122	22	3	8-17.5	399	280	33
80	310	200	160	133	24	3	8-17.5	405	280	43
100	350	235	190	158	28	3	8-22	460	320	69

美标波纹管截止阀

API Bellows Globe valves WJ41(H/Y)150Lb~900Lb

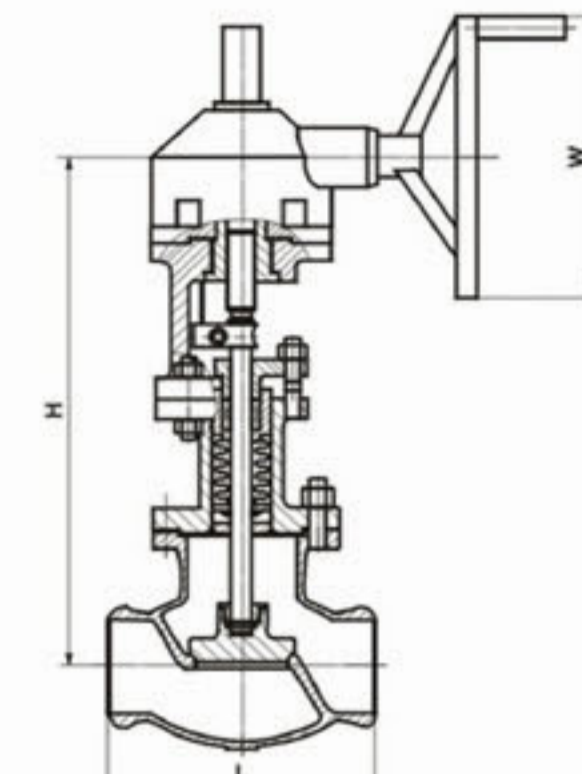
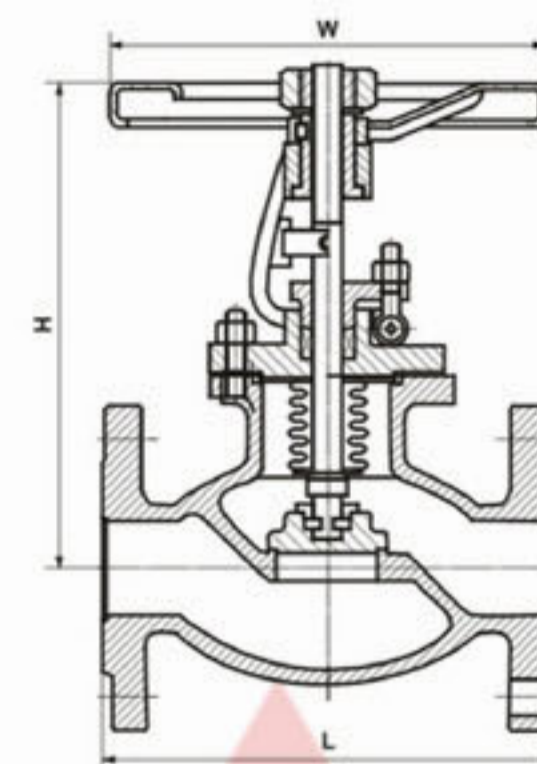

主要外形和连接尺寸 Main External and Connection Dimension

单位Unit:mm

型号Model	WJ41-150LB															
压力等级Pressure	150LB															
口径 Size	mm	15	20	25	32	40	50	65	80	100	125	150	200	250	300	350
	inch	1/2	3/4	1	1 1/4	1 1/2	2	2 1/2	3	4	5	6	8	10	12	14
L	108	117	127	140	165	203	216	241	292	356	406	495	622	698	787	
H	241	241	241	280	286	368	387	400	457	520	609	698	762	876	990	
W	120	140	140	180	200	220	260	480	300	320	340	400	450	450	450	
重量(kg)Weight	4	5	6	10	13	18	30	35	55	75	104	200	300	390	610	
型号Model	WJ41-300LB															
压力等级Pressure	300LB															
口径 Size	mm	15	20	25	32	40	50	65	80	100	125	150	200	250	300	350
	inch	1/2	3/4	1	1 1/4	1 1/2	2	2 1/2	3	4	5	6	8	10	12	14
L	152	178	203	215	229	267	292	318	356	400	444	559	622	711	762	
H	241	241	283	320	322	399	438	450	584	610	660	762	850	1085	1187	
W	120	140	140	180	200	220	260	280	300	320	340	400	450	450	450	
重量(kg)Weight	6	7	10	15	20	25	30	52	88	115	160	259	420	595	876	
型号Model	WJ41-600LB															
压力等级Pressure	600LB															
口径 Size	mm	15	20	25	32	40	50	65	80	100	125	150	200	250	300	350
	inch	1/2	3/4	1	1 1/4	1 1/2	2	2 1/2	3	4	5	6	8	10	12	14
L	165	190	216	229	241	292	330	356	432	508	559	660	787	838	889	
H	240	280	320	320	390	430	480	508	635	750	914	1016	1219	1330	1560	
W	140	140	160	160	180	180	250	250	350	400	450	500	600	720	760	
重量(kg)Weight	7	10	16	22	29	35	50	90	150	230	300	510	850	1120	1400	
型号Model	WJ41-900LB															
压力等级Pressure	900LB															
口径 Size	mm	15	20	25	32	40	50	65	80	100	125	150	200	250	300	350
	inch	1/2	3/4	1	1 1/4	1 1/2	2	2 1/2	3	4	5	6	8	10	12	14
L	216	229	254	279	305	368	419	381	457	559	610	737	838	965	1029	
H	280	330	350	430	508	569	430	635	774	860	1040	1330	1560	1650	1780	
W	160	160	180	180	350	250	320	350	450	550	600	720	760	820	890	
重量(kg)Weight	10	16	23	37	49	65	75	120	200	350	410	790	1300	1500	1800	



德标截止阀  
DIN Globe valves

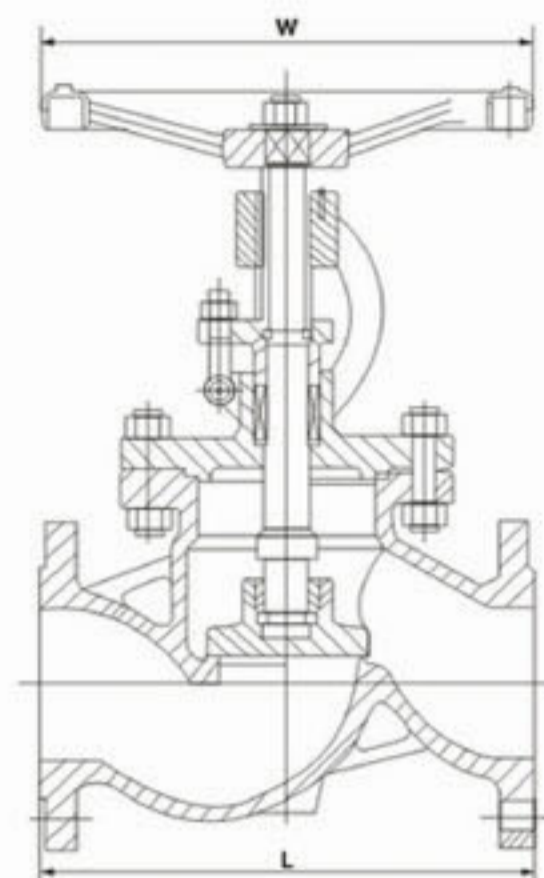

产品执行标准 Production enforce standard

结构形式 Structural formation	BB-BG-OS & Y
驱动方式 Driving maner	手动 Hand-operated
	电动 Electric-actuated
设计标准 Design standard	DIN3356
结构长度 Face to face	DIN3202
连接法兰 Flange ends	DIN2543-2545
实验和检验 Test & inspection	DIN3230

注:系列阀门连接法兰可根据用户要求设计制造。

Notes: The size of serial, valve connecting flange can design according to customer's requirement.

产品性能规范 Chief property and specification

公称压力(MPa) Nominal pressure	壳体试验压力(MPa) Shell test	密封试验压力(MPa) Sealing test	适用温度(°C) Suitable temp	适用介质 Applicable medium
1.6	2.4	1.76	-110~600°C	水、蒸汽、油品等 Water oil & gas
2.5	3.75	2.75		
4.0	6.0	4.4		
6.4	9.6	7.04		

主要零部件材料 Main Part Material

壳体 Body	GS-C25								1.4308		
阀瓣 Disc	GS-C25		1.4308		1.4408		Monel				
阀杆 Stem	13Cr		1.4308		1.4408		Monel				
阀瓣密封面 Wedge disc sealing face	13Cr	13Cr	STL	1.4308	STL	1.4408	STL	Monel	1.4308	1.4308	STL
阀座密封面 Seat ring sealing face	13Cr	STL	STL	1.4308	STL	1.4408	STL	Monel	1.4308	STL	STL
壳体 Body	1.4408				1.4306				1.4301		
阀瓣 Disc	1.4408				1.4306				1.4301		
阀杆 Stem	1.4408				1.4306				1.4301		
阀瓣密封面 Wedge disc sealing face	1.4408	1.4408	STL	1.4306	1.4306	STL	1.4301	1.4301	STL	STL	
阀座密封面 Seat ring sealing face	1.4408	STL	STL	1.4306	STL	STL	1.4301	STL	STL	STL	

德标截止阀F1系列  
DIN Globe valves

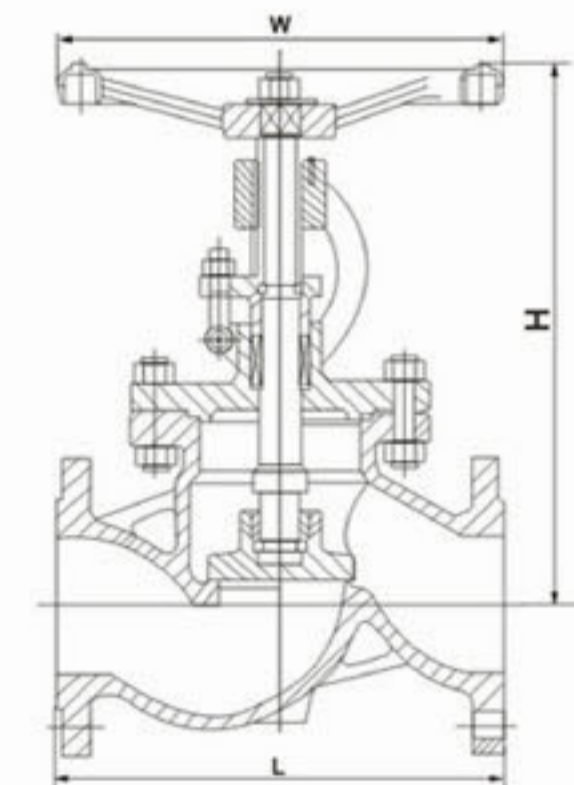

主要外形和连接尺寸 Main External and Connection Dimension

压力等级 Pressure(MPa)		PN1.6MPa															
口径 Size	mm	15	20	25	32	40	50	65	80	100	125	150	200	250	300	350	400
L		130	150	160	180	200	230	290	310	350	400	450	600	730	850	980	1100
H		240	260	276	285	300	305	354	402	437	496	541	699	815	914	1189	1350
W		120	140	160	160	180	200	200	750	250	300	350	400	450	500	550	600
重量(kg)Weight		8	10	12	16	17	20	30	38	56	75	100	182	278	398	500	618

压力等级 Pressure(MPa)		PN2.5MPa															
口径 Size	mm	15	20	25	32	40	50	65	80	100	125	150	200	250	300	350	400
L		130	150	160	180	200	230	290	310	350	400	450	600	730	850	980	1100
H		240	260	276	285	300	325	363	415	453	505	556	744	864	948	1269	1450
W		120	140	160	160	180	200	200	250	300	350	400	450	500	550	600	600
重量(kg)Weight		8	10	12	16	17	20	30	39	58	80	101	190	290	405	510	650

压力等级 Pressure(MPa)		PN4.0MPa															
口径 Size	mm	15	20	25	32	40	50	65	80	100	125	150	200	250	300	350	400
L		130	150	160	180	200	230	290	310	350	400	450	600	730	850	980	1100
H		240	260	276	285	300	325	363	430	480	532	589	783	888	965	1285	1512
W		120	140	160	160	180	200	200	250	300	350	400	450	500	550	600	600
重量(kg)Weight		8	10	12	16	17	22	31	41.5	61	83	110	210	318.5	430	520	680



德标截止阀F2系列  
 DIN Globe valves

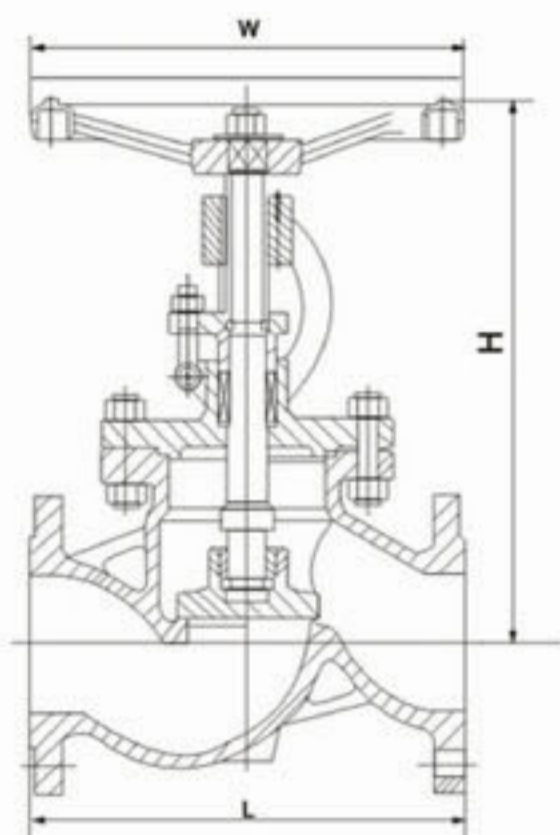

主要外形和连接尺寸 Main External and Connection Dimension

压力等级 Pressure(MPa)		PN6.4MPa															
口径 Size	mm	15	20	25	32	40	50	65	80	100	125	150	200	250	300	350	400
L		130	150	160	180	200	230	340	380	430	500	550	650	775	900	1025	1150
H		240	260	276	285	300	305	354	402	437	496	541	699	815	914	1189	1350
W		120	140	160	160	180	200	200	750	250	300	350	400	450	500	550	600
重量(kg)Weight		8	10	12	16	17	20	30	38	56	75	100	182	278	398	500	618

压力等级 Pressure(MPa)		PN10.0MPa															
口径 Size	mm	15	20	25	32	40	50	65	80	100	125	150	200	250	300	350	400
L		130	150	160	180	200	300	340	380	450	500	550	650	775	900	1025	1250
H		240	260	276	285	300	325	363	415	453	505	556	744	864	948	1269	1450
W		120	140	160	160	180	200	200	250	300	350	400	450	500	550	600	600
重量(kg)Weight		8	10	12	16	17	20	30	39	58	80	101	190	290	405	510	650

压力等级 Pressure(MPa)		PN16.0MPa															
口径 Size	mm	15	20	25	32	40	50	65	80	100	125	150	200	250	300	350	400
L		130	150	160	180	200	300	340	380	450	500	550	650	775	900	1025	1250
H		240	260	276	285	300	325	370	430	480	532	589	783	888	965	1285	1512
W		120	140	160	160	180	200	200	250	300	350	400	450	500	550	600	600
重量(kg)Weight		8	10	12	16	17	22	31	41.5	61	83	110	210	318.5	430	520	680

德标波纹管截止阀  
 DIN Bellows Globe valves

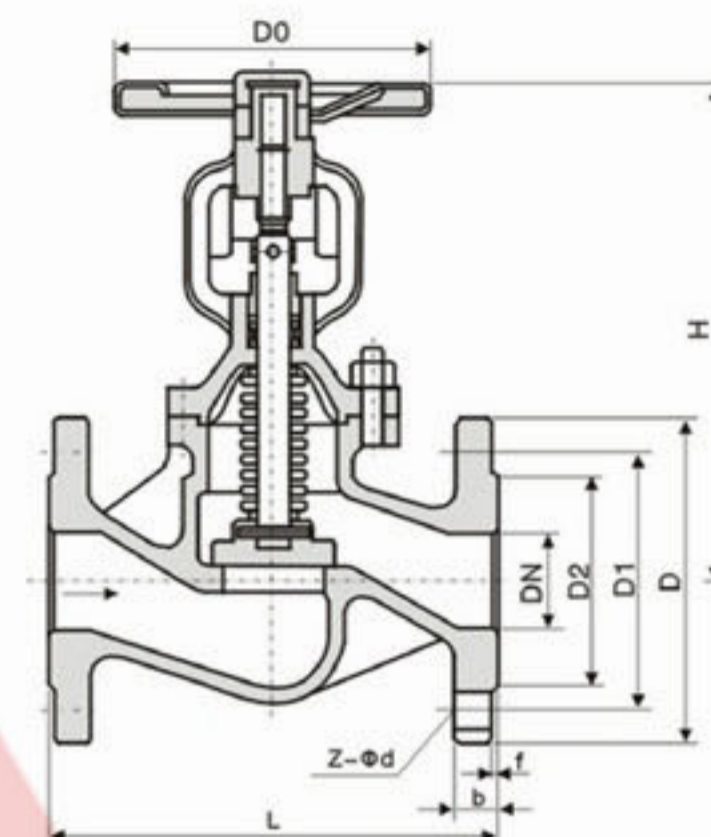

主要外形和连接尺寸 Main External and Connection Dimension

单位Unit:mm

公称通径 DN	L	D	D1	D2	b	f	Z-φd	H	H1	Do	WT(kg)
DIN/WJ41H-16C DIN/WJ41H-16P											
15	130	95	65	45	16	2	4-14	191	197	120	5
20	150	105	75	58	18	2	4-14	191	197	140	7
25	160	115	85	65	18	2	4-14	197	205	140	9
32	180	140	100	78	18	2	4-18	200	208	160	12
40	200	150	110	88	18	3	4-18	218	231	200	16
50	230	165	125	102	20	3	4-18	220	233	200	19
65	290	185	145	122	18	3	4-18	238	254	240	23
80	310	200	160	138	20	3	8-18	257	277	240	30
100	350	220	180	158	20	3	8-18	340	365	320	42
125	400	250	210	188	22	3	8-18	360	392	360	63
150	480	285	240	212	22	3	8-22	390	420	360	90
200	600	340	295	268	24	3	12-22	530	580	500	150
DIN/WJ41H-25C DIN/WJ41H-25P											
15	130	95	65	45	16	2	4-14	191	197	120	5
20	150	105	75	58	18	2	4-14	191	197	160	7
25	160	115	85	68	18	2	4-14	197	205	160	9
32	180	140	100	78	18	2	4-18	200	208	160	12
40	200	150	110	88	18	3	4-18	218	231	200	19
50	230	165	125	102	20	3	4-18	220	233	200	24
65	290	185	145	122	22	3	8-18	238	254	280	33
80	310	200	160	138	24	3	8-18	257	277	280	44
100	350	235	220	162	24	3	8-22	340	332	320	60
125	400	270	250	188	26	3	8-26	360	392	360	72
150	480	300	295	218	28	3	8-26	390	430	360	98
200	600	360	310	278	30	3	12-26	530	580	500	169
DIN/WJ41H-40C DIN/WJ41H-40P											
15	130	95	65	45	16	2	4-14	191	197	120	5
20	150	105	75	58	18	2	4-14	191	197	160	7
25	160	115	85	65	18	2	4-14	197	205	160	9
32	180	140	100	78	18	2	4-18	200	208	160	12
40	200	150	110	88	18	3	4-18	218	231	200	16
50	230	165	125	102	20	3	4-18	220	233	200	23
65	290	185	145	122	22	3	8-18	238	254	280	33
80	310	200	160	138	24	3	8-18	257	277	280	45
100	350	235	220	162	24	3	8-22	340	365	320	69
125	400	270	250	188	26	3	8-26	360	392	360	98
150	480	300	295	218	28	3	8-26	390	430	360	170



日标不锈钢截止阀  
 JIS Stainless steel Globe valves

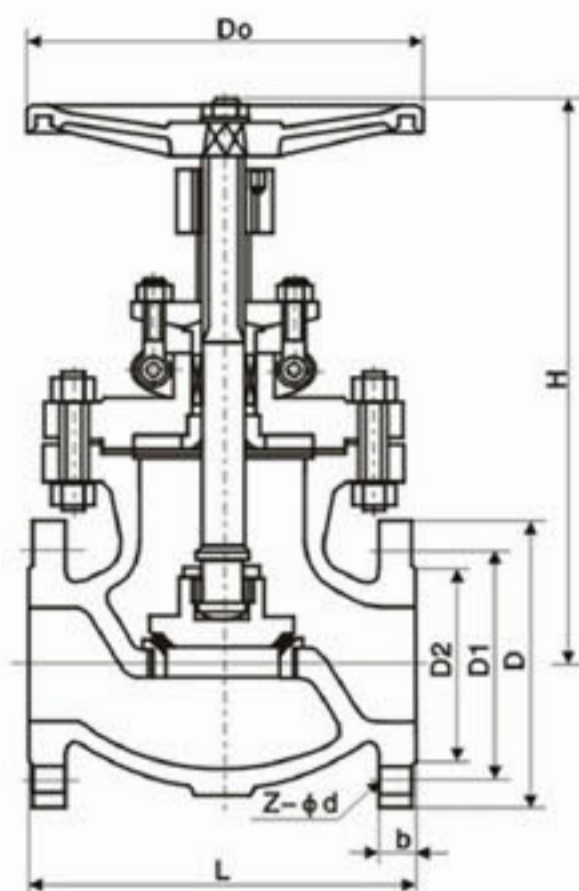

执行标准 Administer Standard

设计与制造 Design and Manufacture	结构长度 Face to Face	法兰尺寸 Flange Dimension	压力-温度 Pressure Temperature Rating	试验-检验 Inspection and Test
JIS B2071 B2081	JIS B2002	JIS B2212 B2214	JIS B2071 B2081	JIS B2003

性能规范 Capability Criterion

阀体材料 Body material	SCPH2-11	SCPH-32	SCS13A	SCS19A	SCS 14A	SCS16A	SCPL1
适用温度 Suitable Temperature	≤425℃	≤540℃	≤275℃	≤200℃	≤275℃	≤200℃	-45~150℃
适用介质 Suitable Medium	水 蒸气 油品 Water Steam Oil Goods		硝酸类 Nitric Acia	醋酸类 Acetic Acid	氨气 液氨 Liquid Ammonia		

规格主要尺寸 Size Main Dimensions

DN		10K							
Mm	In	L	D	D1	D2	b	n-φd	H	D0
50	2	203	155	120	100	16	4-φ19	360	200
65	2 1/2	216	175	140	120	18	4-φ19	380	200
80	3	241	185	150	130	18	8-φ19	415	250
100	4	292	210	175	155	18	8-φ19	465	250
125	5	356	250	210	185	20	8-φ23	515	300
150	6	406	280	240	215	22	8-φ23	545	350
200	8	495	330	290	265	22	12-φ23	675	450
		20K							
Mm	In	L	D	D1	D2	b	n-φd	H	D0
50	2	267	155	120	100	18	8-φ19	420	200
65	2 1/2	292	175	140	120	20	8-φ19	465	250
80	3	318	200	160	135	22	8-φ23	490	300
100	4	356	225	185	160	24	8-φ23	590	350
125	5	400	270	225	195	26	8-φ25	690	400
150	6	444	305	260	230	28	12-φ25	760	450
200	8	559	350	305	275	30	12-φ25	1070	450

电站截止阀

Power-station Globe valves

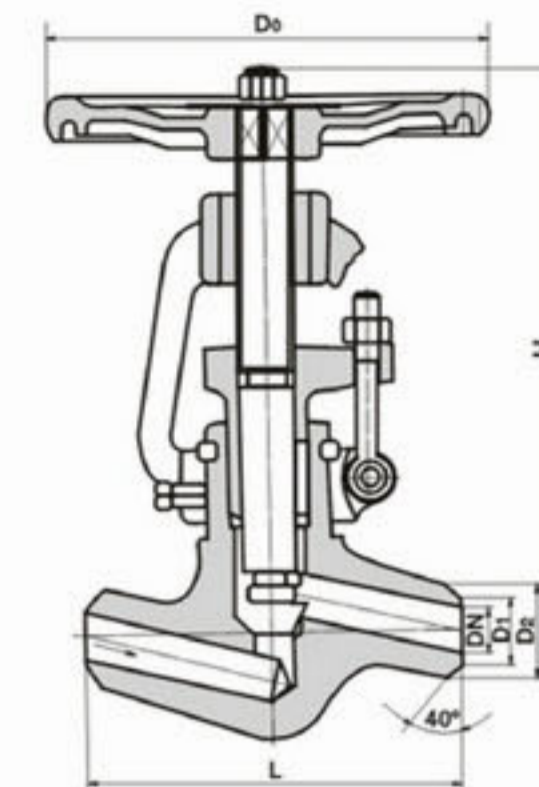

产品执行标准 Production enforce standard

产品规范 Product Specification	设计规范 Design Spec	结构长度 Face to Face	连接法兰 Flange Dnd	试验与检验 Test & Check	压力-温度 Pressure-Temp	产品标识 Marking	供货规范 Supply
	JB/T3595/E101	E101	78DG	E101	JB/T3595	GB/T12220	E101

产品性能规范 Chief property and specification

产品型号 Product type	试验压力 PN(MPa) Nominal pressure	试验压力 (Mpa) Test pressure		工作压力 (Mpa) Working pressure			工作温度(°C) Working temperature	适用介质 Applicable medium
		壳体强度 Shell strength test	密封 Sealing	P54	P55	P57		
J61Y-100	10	15	11	/	/	/	≤450	水、蒸气、油品 Water, steam, oil goods
J61Y-200	20	30	22	/	/	/		
J61Y-250	25	38	28	/	/	/		
J61Y-320	32	48	36	/	/	/		
J61Y-P54/100V	/	30	22	10	/	/	≤540	蒸汽 Steam
J61Y-P54/140V	/	38	28	14	/	/		
J61Y-P54/170V	/	48	36	17	/	/		
J61Y-P54/100V	/	38	28	/	10	/	≤555	
J61Y-P54/140V	/	48	36	/	14	/		
J61Y-P54/170V	/	53	39	/	17	/		
J61Y-P54/100V	/	48	36	/	/	10	≤570	
J61Y-P54/140V	/	55	40	/	/	14		
J61Y-P54/170V	/	60	44	/	/	17		

主要零部件材料 Main Part Material

零件名称 Part Name	零件材料 Part Material		
阀体 Body	WCB	WC6	WC9
阀盖 Bonnet	25	120Cr1Mo1VA	
闸板 Wedge	25	20Cr1Mo1VA	20Cr1Mo1VA
阀杆 Stem	1Cr17Ni2	20Cr1Mo1VA	
阀座 Seat	25	12Cr1MoVA	
密封副 Hard Trim	STL+STL	STL+STL	STL+STL
填料 Paking			
垫片 Gasket	S软钢/柔性石墨 S Soft-Iron/Flexible Graphite	S软钢 S Soft-Iron	F软钢 F Soft-Iron
适用温度 Suitable Temp	-29 ~ 425℃		
适用介质 Suitable Medium	水、油品、蒸气 Water, Oil, Steam		蒸气、油品 Steam, Oil





电站截止阀

Power-station Globe valves J61(H/Y)/J961(H/Y)-200~320(P54100V~P54195V)

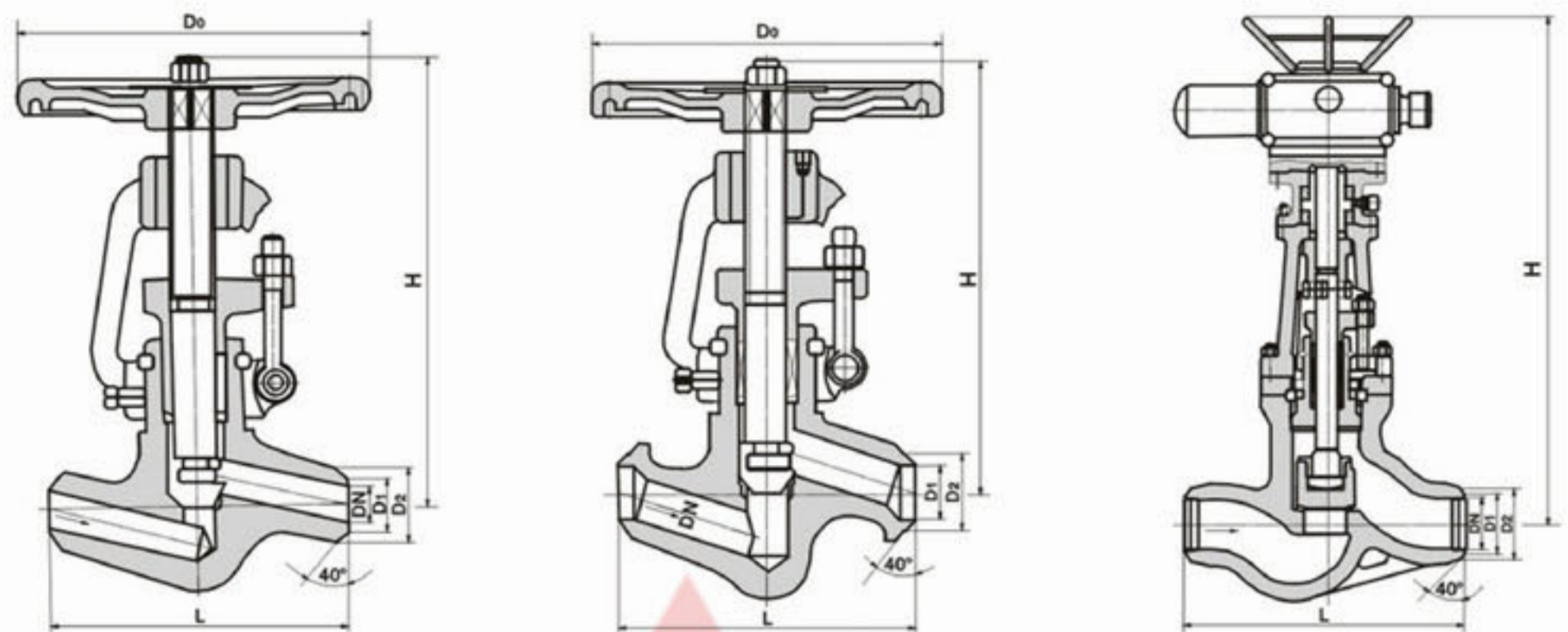

主要外形和连接尺寸 Main External and Connection Dimension

单位Unit:mm

公称通径 DN	主要外形尺寸和连接尺寸 (mm) Main external and connecting dimensions				WT(Kg)
	L	D1	D2	H	
J61H-200 J61Y-200 J961H-200 J961Y-200					
20	170	22	42	480	38
25	170	27	42	520	41
32	200	34	52	728	58
50	350	53	76	728	89
80	500	86	108	798	135
100	600	107	161	890	190
J61Y-250 J61Y-320 J961H-250 J961Y-320					
20	150	25	40	576	47
25	170	27	42	585	49
32	180	32	55	606	52
50	250	50	83	722	73
80	470	80	105	895	225
100	600	100	142	1179	296

主要外形和连接尺寸 Main External and Connection Dimension

单位Unit:mm

公称通径 DN	主要外形尺寸和连接尺寸 (mm) Main external and connecting dimensions				WT(Kg)
	L	D1	D2	H	
J61Y-P54100V J61Y-P54140V J961Y-P54100V J961Y-P54140V					
20	170	22	42	480	38
25	170	27	42	520	41
32	200	34	52	728	58
50	350	53	76	728	89
80	500	86	108	798	135
100	600	107	161	890	190
J61Y-P54170V J61Y-P54195V J961Y-P54170V J961Y-P54195V					
20	150	25	40	576	47
25	170	27	42	585	49
32	180	32	55	606	52
50	250	50	83	722	73
80	470	80	105	895	225
100	600	100	142	1179	296

水封截止阀

Water-sealed Globe valves J41W/Y-16P/R/I

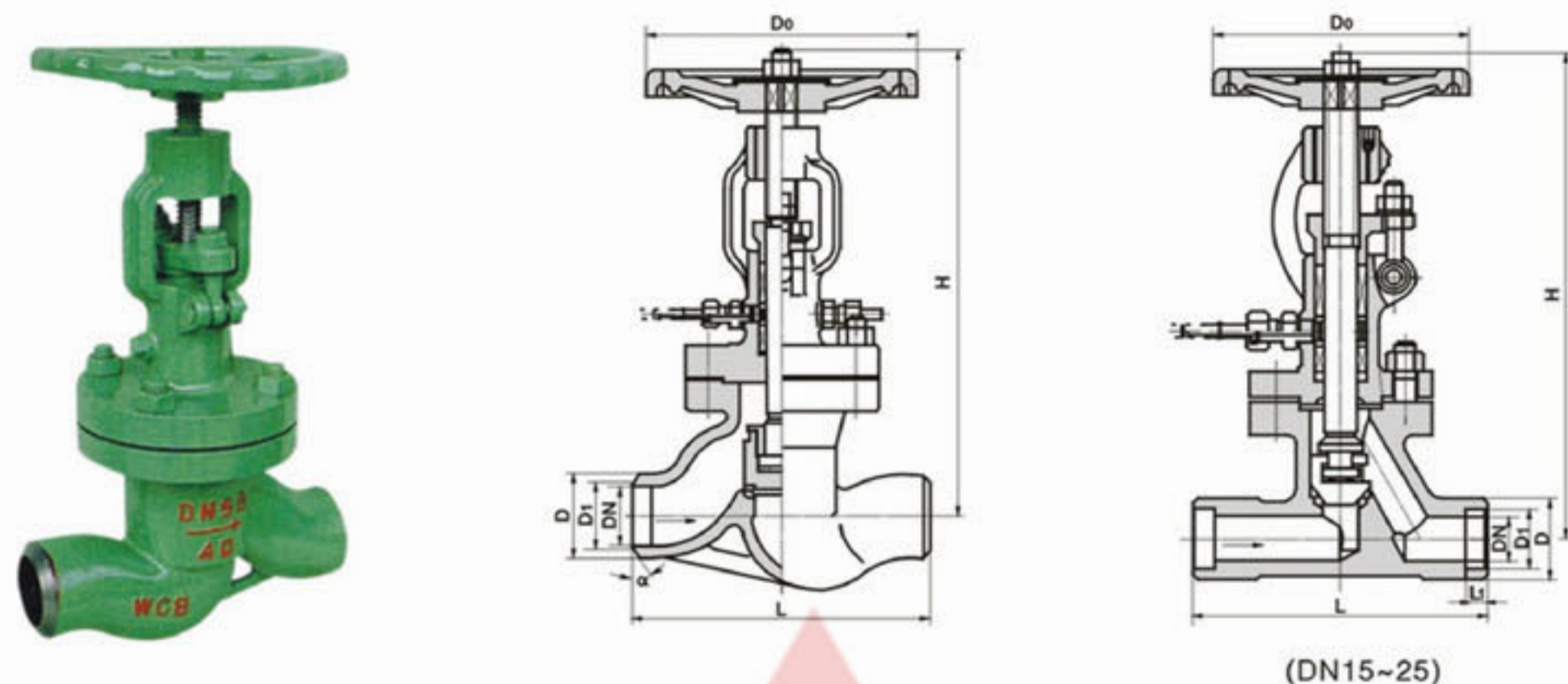

主要外形和连接尺寸 Main External and Connection Dimension

单位Unit:mm

公称通径 DN	主要外形尺寸和连接尺寸 (mm) Main external and connecting dimensions								WT(Kg)
	L	D	D1	D0	L1	H	W	a	
DS/J61H-25									
10	130	36	15	10	-	10	255	120	4.8
15	130	36	19	15	-	11	257	120	5.0
20	150	44	26	20	-	11	267	140	7.3
25	160	44	33	24	-	12	269	140	8.2
32	180	48	34	32	37° 30'	-	255	180	12
40	200	55	40	38	37° 30'	-	295	200	15
50	230	64	50	46	37° 30'	-	354	250	25
65	290	82	65	64	37° 30'	-	400	250	38.5
80	310	94	78	74	37° 30'	-	425	300	49
100	350	117	97	95	37° 30'	-	468	350	64
125	400	144	122	120	37° 30'	-	475	400	83
150	480	170	148	145	37° 30'	-	611	400	94
200	600	220	197	193	37° 30'	-	721	400	152
DS/J61H-40									
10	130	38	15	10	37° 30'	-	255	120	5.3
15	130	38	19	15	37° 30'	-	257	120	5.7
25	150	47	26	20	37° 30'	-	267	140	7.6
20	160	47	33	24	37° 30'	-	270	160	8.8
32	180	53	34	32	37° 30'	-	257	160	13.2
40	200	57	40	38	37° 30'	-	297	200	16.5
50	230	68	50	46	37° 30'	-	354	250	26
65	290	85	65	62	37° 30'	-	405	280	41.3
80	310	98	78	74	37° 30'	-	427	320	51.5
100	350	122	97	95	37° 30'	-	470	350	69
125	400	148	122	120	37° 30'	-	475	400	89
150	480	176	148	145	37° 30'	-	614	400	98
DS/J61H-64									
10	130	38	15	10	37° 30'	-	255	140	6
15	210	38	19	15	37° 30'	-	257	140	6.4
20	230	47	26	19	37° 30'	-	269	160	8.4
25	230	47	33	24	37° 30'	-	273	180	9.6
32	260	53	34	32	37° 30'	-	259	200	23
40	260	57	40	38	37° 30'	-	297	250	34
50	300	70	50	46	37° 30'	-	256	280	46
65	340	86	65	62	37° 30'	-	405	320	67
80	380	100	78	74	37° 30'	-	429	360	85
100	430	124	97	95	37° 30'	-	477	400	97



仪表针形截止阀  
Meter-needle type

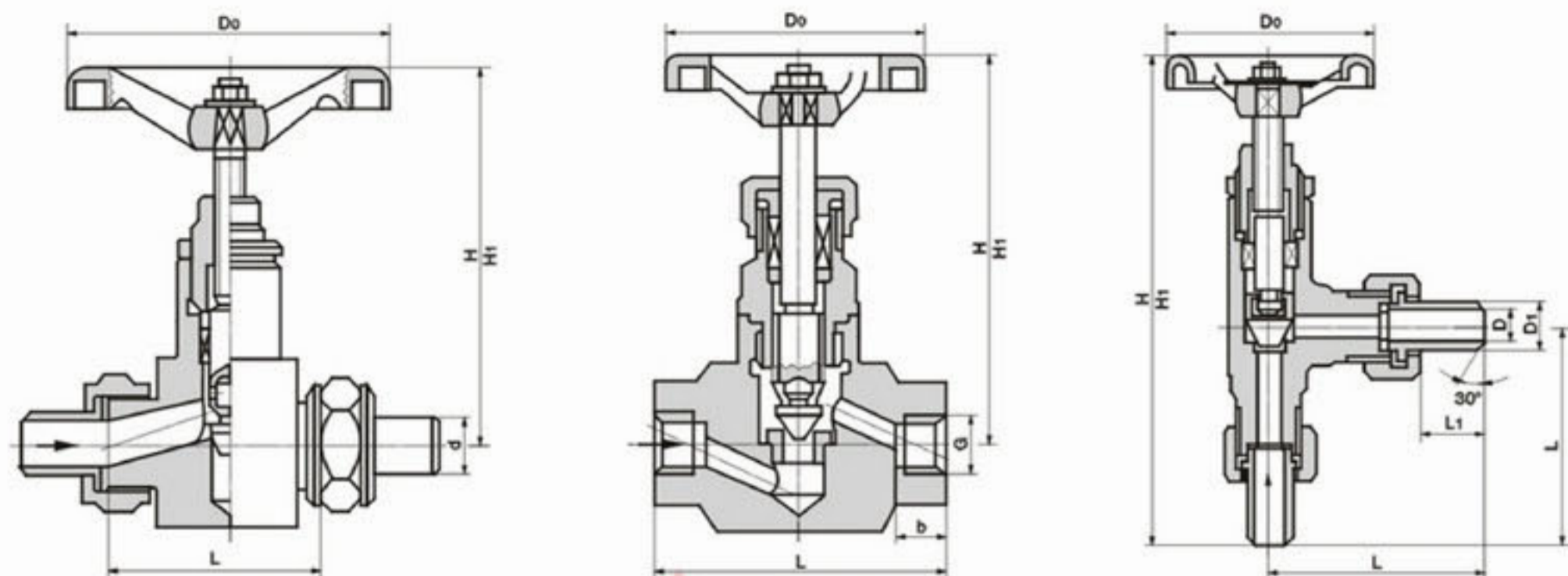

产品性能规范 Chief property and specification

公称压力 PN Nominal pressure	2.5	4.0	6.4	16	25	32	Mpa
壳体试验压力 Shell test pressure	3.75	6.0	9.6	24	37.5	48	
高压密封试验压力 Hing pressure seat test	2.75	4.4	7.04	17.6	27.5	35.2	
低压气密封试验压力 Low pressure seat test	0.5~0.7						
适用介质 Appilcable medium	C,水、油品、蒸气 Water,oil,steam			P硝酸类 Nitric acid		R醋酸类 Acetic acid	
适用温度 Appilcable temperature	C,P,R I						≤450° ≤560° ≤540°

主要外形和连接尺寸 Main External and Connection Dimension

DN	d	H	H1	L	D0
6	12	112	122	62	65
10	14	124	134	76	65
25	22	145	160	90	100
20	28	160	160	100	100
25	34	185	210	105	100

主要外形和连接尺寸 Main External and Connection Dimension

型号 Type	DN	G(in)	L	b	H1	H2	D0
J13H-25 J13H-40 J13W-25P J13W-40R	15	1/2	90	18	190	201	65
	20	3/4	110	22	214	227	65
	25	1	130	26	235	250	80
	32	5/4	160	27	267	283	100
	40	3/2	190	30	305	327	120
J13H-40 J13H-160 J13W-320 J13W-40P J13W-160P J13W-320P	15	1/2	90	18	190	201	65
	20	3/4	110	22	214	227	65
	25	1	130	26	235	250	80
	32	5/4	160	27	267	283	100
	40	3/2	190	30	305	327	120

型号 Type	DN	D	D1	L	L1	H	H1	D0
J24H-25 J24N-40 J24H-150 J24W-25P J24W-160P	6	9	14	71	20	152	158	65
	10	12	18	71	22	172	180	80
	15	16	22	93	26	285	292	120
	20	22	28	107	31	335	345	140
	25	27	34	118	32	355	368	140

低温截止阀门

Cryogenic Globe valves J41/641/9B41Y-16-40C/P/R

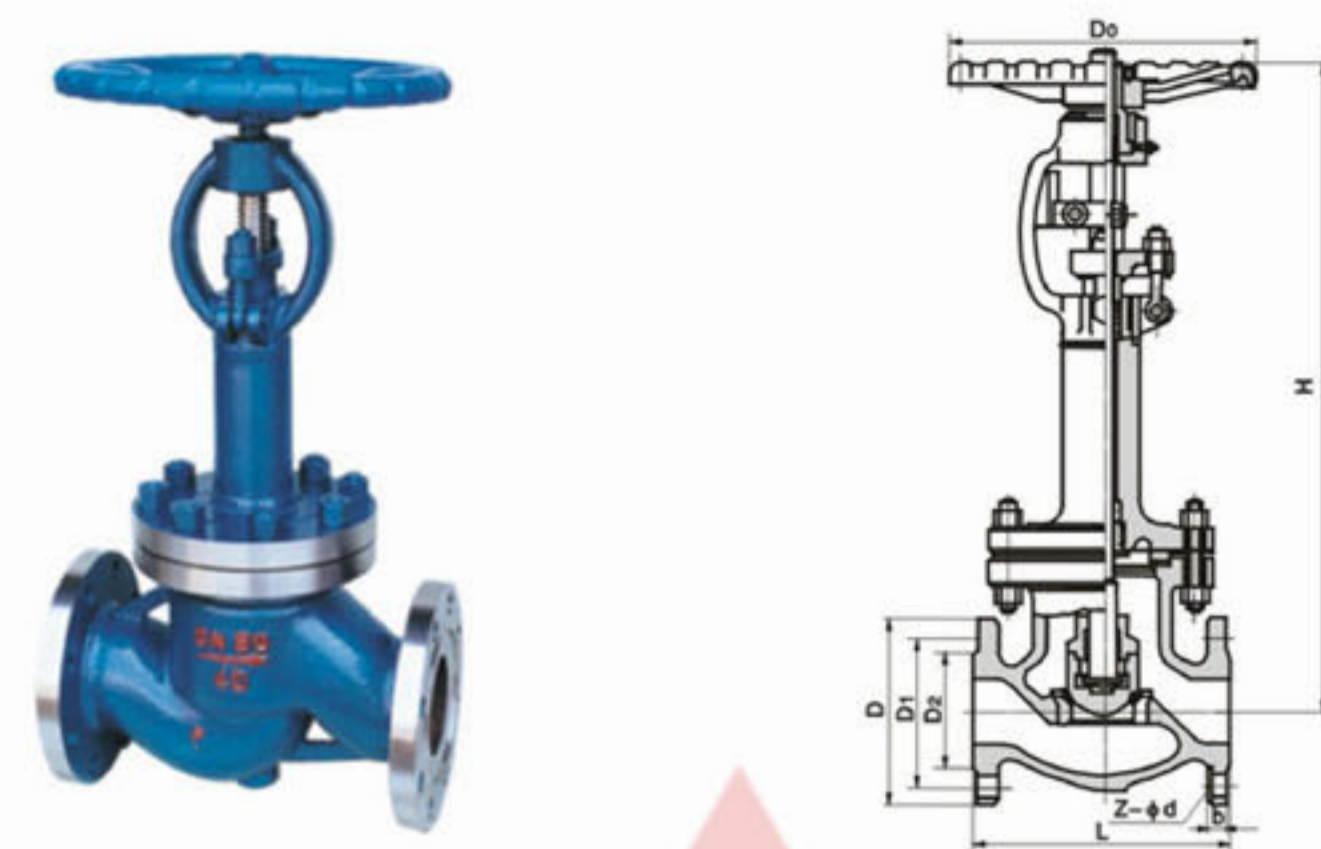

主要外形和连接尺寸 Main External and Connection Dimension

单位 Unit:mm

公称通径 DN	主要外形尺寸和连接尺寸 (mm) Main external and connecting dimensions									WT (Kg)		
	L	D	D1	D2	b	Z-φd	D0	-46°C	-101°C		-196°C	
DJ41Y-16C DJ41Y-16P DJ41Y-16R DJ641Y-16C DJ641Y-16P DJ641Y-16R DJ9B41Y-16C DJ9B41Y-16P DJ9B41Y-16R	50	230	160	125	100	16	240	4-φ18	460	480	520	15
	65	290	180	145	120	18	280	4-φ18	475	505	525	23
	80	310	195	160	135	20	280	8-φ18	520	550	590	28
	100	350	215	180	155	20	320	8-φ18	545	575	615	32
	125	400	245	210	185	22	360	8-φ18	590	620	660	88
	150	480	280	240	210	24	400	8-φ23	650	680	730	96
	200	600	335	295	265	26	400	12-φ23	850	880	930	155
	250	730	405	355	320	30	450	12-φ25	956	986	1036	425
	300	850	460	410	375	30	500	12-φ25	1095	1125	1175	641
DJ41Y-25 DJ41Y-25P DJ41Y-16R DJ641Y-25C DJ641Y-25P DJ641Y-25R DJ9B41Y-25C DJ9B41Y-25P DJ9B41Y-25R	50	230	160	125	100	20	240	4-φ18	460	480	520	16
	65	290	180	145	120	22	280	8-φ18	475	505	525	23
	80	310	195	160	135	22	280	8-φ18	520	550	590	29
	100	350	230	190	160	24	320	8-φ23	545	575	615	32
	125	400	270	220	188	28	360	8-φ25	590	620	660	90
	150	480	300	250	218	30	400	8-φ25	650	680	730	98
	200	600	360	310	278	34	400	12-φ25	850	880	930	159
	250	730	425	370	332	36	450	12-φ30	956	986	1036	436
	300	850	485	430	390	40	500	16-φ30	1095	1125	1175	657
DJ41Y-40 DJ41Y-40P DJ41Y-40R DJ641Y-40C DJ641Y-40P DJ641Y-40R DJ9B41Y-40C DJ9B41Y-40P DJ9B41Y-40R	50	230	160	125	100	88	240	4-φ18	483	504	546	16
	65	290	180	145	120	110	280	8-φ18	499	530	551	24
	80	310	195	160	135	21	280	8-φ18	546	578	620	30
	100	350	230	190	160	150	320	8-φ23	572	604	646	33
	125	400	270	220	188	176	360	8-φ25	620	651	693	93
	150	480	300	250	218	204	400	8-φ25	683	741	767	100
	200	600	360	320	282	260	400	12-φ30	893	924	977	163
	250	730	425	385	345	313	450	12-φ33	1004	1035	1088	447
	300	850	485	450	408	364	500	16-φ30	1150	1181	1234	673



保温截止阀

Jacket Globe valves BJ45H/Y-15-40P/R

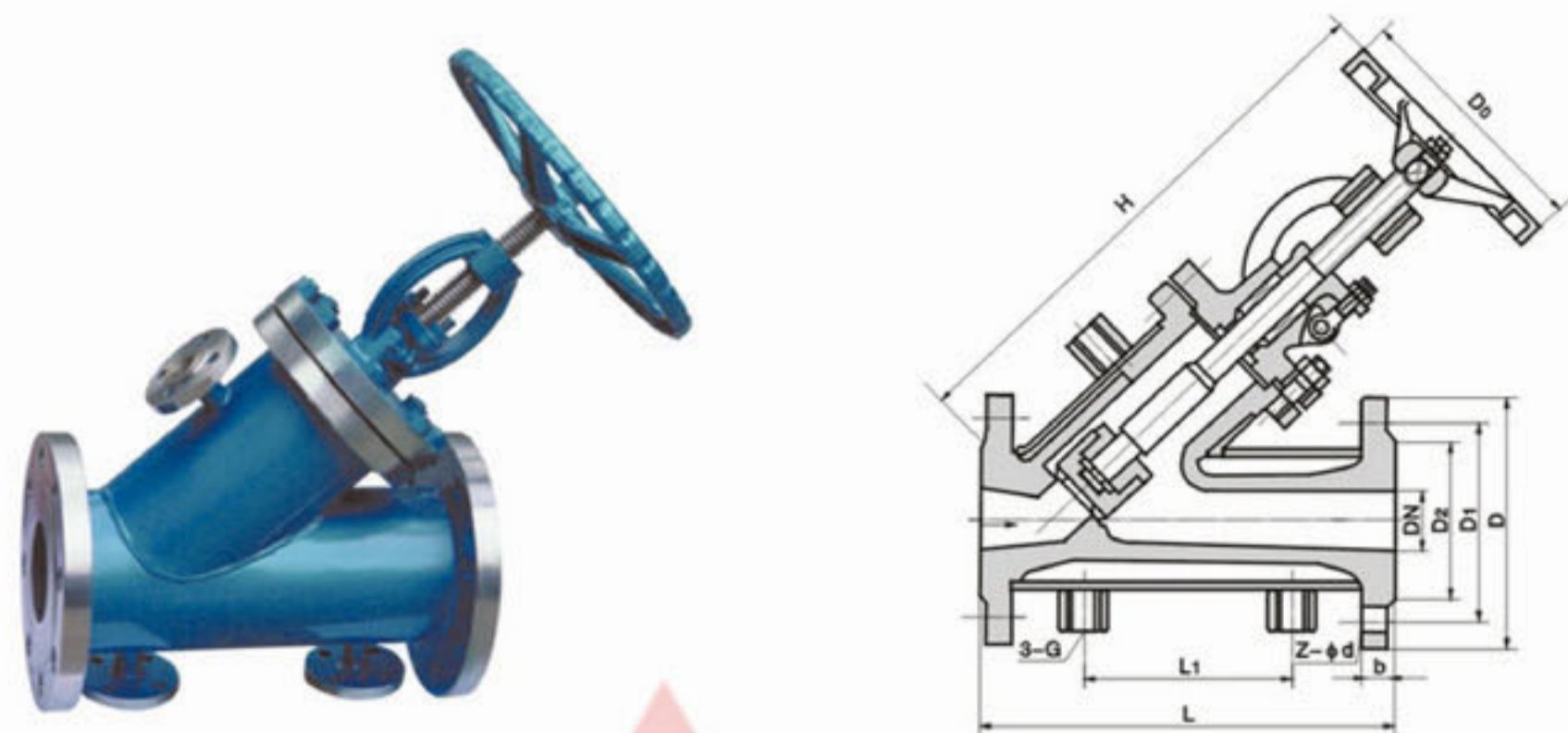

主要外形和连接尺寸 Main External and Connection Dimension

单位Unit:mm

公称通径 DN	PN2.5/4.0MPa							G	H	D0	WT (Kg)
	L	D	D1	D2	D6	b	Z-φd				
BJ45H-25 BJ45Y-25P BJ45Y-25R BJ45Y-25R3											
15	200	105	75	55	-	16	4-φ14	1/2"	210	120	15
20	220	115	85	65	-	16	4-φ14	1/2"	240	140	21
25	220	135	100	78	-	18	4-φ18	1/2"	250	160	25
32	250	145	110	85	-	18	4-φ18	1/2"	270	160	30
40	270	160	125	100	-	20	4-φ18	1/2"	310	160	36
50	300	180	145	120	-	22	8-φ18	3/4"	330	240	40
65	350	195	160	135	-	22	8-φ18	3/4"	360	240	54
80	380	230	190	160	-	24	8-φ23	3/4"	400	280	70
100	430	270	220	188	-	28	8-φ25	1"	480	320	100
125	490	300	250	218	-	30	8-φ25	1"	550	360	130
150	570	330	280	248	-	32	12-φ25	1"	620	300	170
200	690	395	340	302	-	36	12-φ30	1"	750	400	250
BJ45H-40 BJ45Y-40P BJ45Y-40R BJ45Y-40R3											
15	200	105	75	55	51	16	4-φ14	1/2"	210	120	18
20	220	115	85	65	58	16	4-φ14	1/2"	240	140	21
25	220	135	100	78	66	18	4-φ18	1/2"	250	160	25
32	250	145	110	85	76	18	4-φ18	1/2"	270	160	33
40	270	160	125	100	88	20	4-φ18	1/2"	310	160	41
50	300	180	145	120	110	22	8-φ18	3/4"	330	240	45
65	350	195	160	135	121	22	8-φ18	3/4"	360	240	62
80	380	230	190	160	150	24	8-φ23	3/4"	400	280	80
100	430	270	220	188	176	28	8-φ25	1"	480	320	100
125	490	300	250	218	204	30	8-φ25	1"	550	360	130
150	570	350	295	258	234	34	12-φ30	1"	620	360	185
200	690	415	355	315	287	40	12-φ34	1"	750	400	168

锻钢截止阀

Forged Globe valves J41/11/61 H/Y-16-160 CJ41H-25

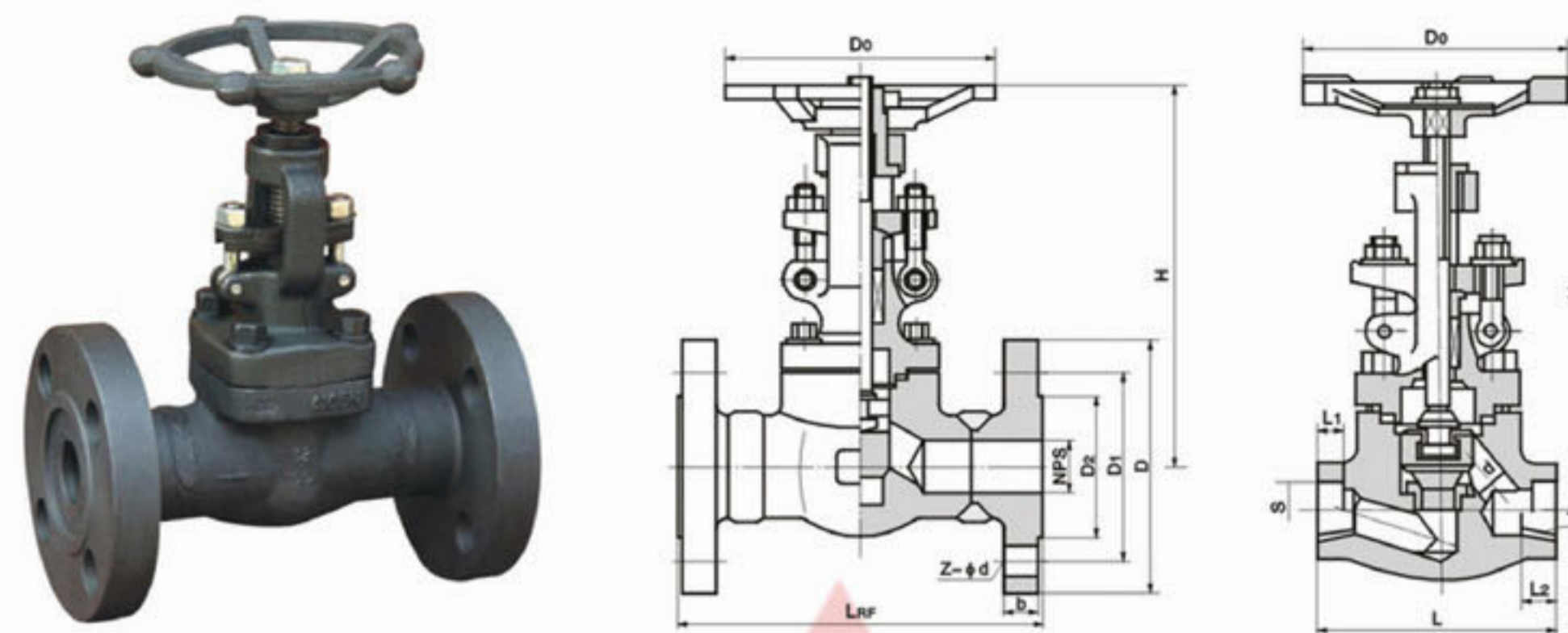

主要外形和连接尺寸 Main External and Connection Dimension

单位Unit:mm

公称通径 DN	主要外形尺寸和连接尺寸 (mm) Main external and connecting dimensions									WT (Kg)
	L	d	S	L1	T	L2	H	D0		
J41H-16 CJ41H-25 J41H-40 J11H-16 CJ11H-25 J11H-40 J61H-16C J61H-25 J61H-40										
15	90	13	22.5	10	1/2	15	159	98		6.9
20	100	18	28.5	11	3/4	17	190	112		9.8
25	120	23	34.5	12	1	19	208	126		13.5
32	140	29	43	14	1 1/4	21	216	166		19.5
40	170	36	49	15	1 1/2	21	247	188		28.5
50	200	46	61	16	2	25	290	220		30.3
J41H-64 J11H-64 J61H-64										
15	90	13	22.5	10	1/2	15	159	98		7.7
20	100	18	28.5	11	3/4	17	190	112		11.3
25	120	23	34.5	12	1	19	208	126		16.8
32	140	29	43	14	1 1/4	21	216	166		21.2
40	170	36	49	15	1 1/2	21	258	188		32.6
50	210	46	61	16	2	25	405	220		35
J41Y-100 J11Y-100 J61Y-100										
15	90	13	22.5	10	1/2	15	159	98		7.8
20	100	18	28.5	11	3/4	17	190	112		12.5
25	120	23	34.5	12	1	19	208	126		17.5
32	140	29	43	14	1 1/4	21	216	166		23.5
40	170	36	49	15	1 1/2	21	258	188		38.5
50	200	46	61	16	2	25	405	220		42.2
J41Y-160 J11Y-160 J61Y-160										
15	90	13	22.5	10	1/2	15	159	98		8.2
20	100	18	28.5	11	3/4	17	190	112		13.8
25	120	23	34.5	12	1	19	208	126		18.5
32	140	29	43	14	1 1/4	21	216	188		25.5
40	170	36	49	15	1 1/2	21	258	220		41.5
50	210	46	61	16	2	25	405	220		49

主要外形和连接尺寸 Main External and Connection Dimension

单位Unit:mm



氧气专用截止阀

Oxygen Globe valves YJ41H-25-40P/T

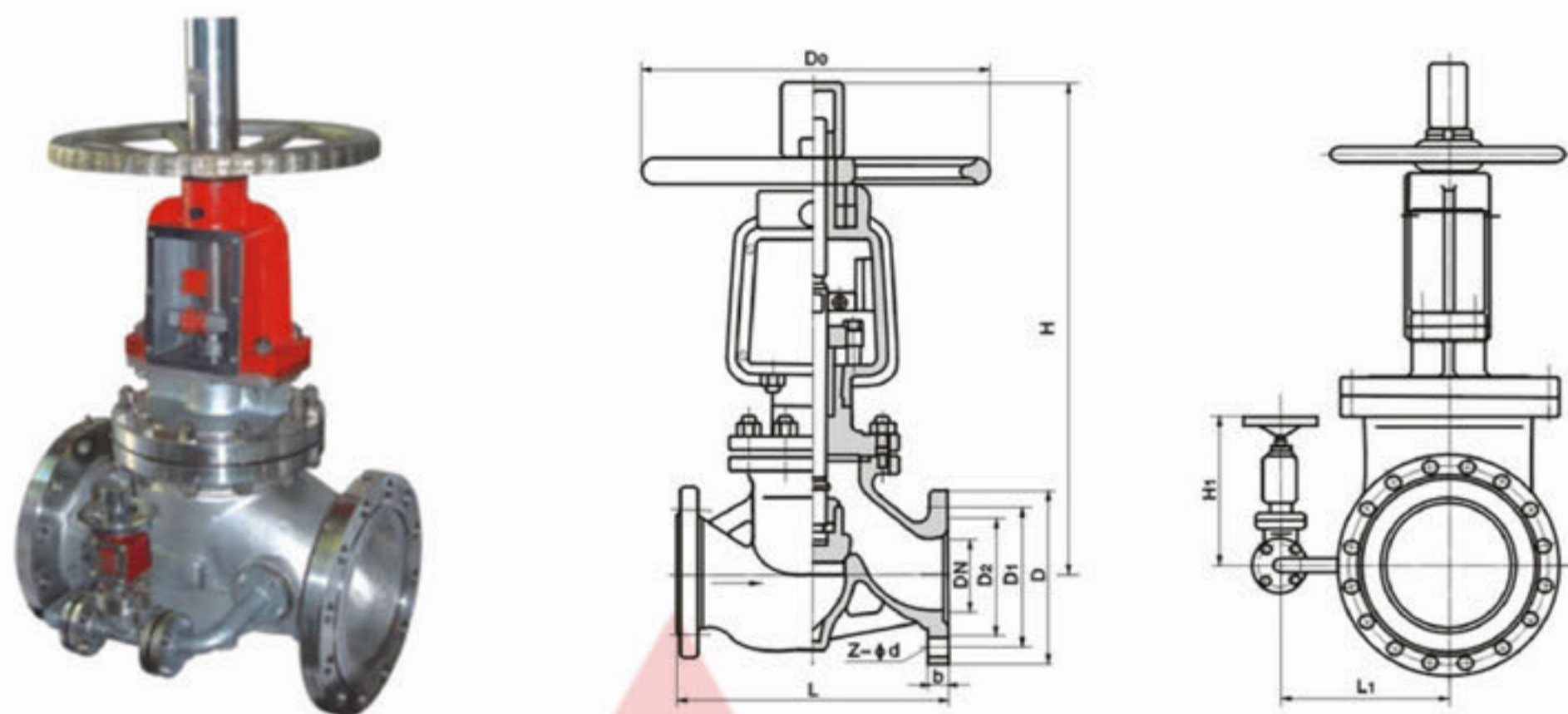

主要外形和连接尺寸 Main External and Connection Dimension

单位Unit:mm

公称通径 DN	主要外形尺寸和连接尺寸 (mm) Main external and connecting dimensions										WT (Kg)
	L	D	D1	D2	b	Z-φd	D0	H	H1	L1	
YJ41W-25P YJ41W-25T											
15	130	95	65	45	16	4-14	100	190	-	-	5
20	150	105	75	55	16	4-14	100	213	-	-	6.5
25	160	115	85	65	16	4-18	125	236	-	-	7
32	190	135	100	73	18	4-18	180	312	-	-	13.5
40	200	145	110	85	18	4-18	160	328	-	-	16
50	230	160	125	100	20	8-18	320	450	-	-	32
65	290	180	145	120	22	8-18	360	530	-	-	46
80	310	195	160	135	22	8-18	400	560	-	-	60
100	350	230	190	160	24	8-23	450	618	-	-	80
125	400	270	220	188	28	8-25	450	675	-	-	107
150	480	300	250	218	30	8-25	560	743	-	-	134
200	600	360	310	278	34	12-25	640	850	-	-	268.7
250	650	425	370	332	36	12-30	720	975	340	330	449
300	750	485	430	390	40	16-30	800	1115	340	415	663
400	950	610	550	505	43	16-34	900	1380	340	465	1170

氧气专用截止阀

Oxygen Globe valves YJ41H-25-40P/T

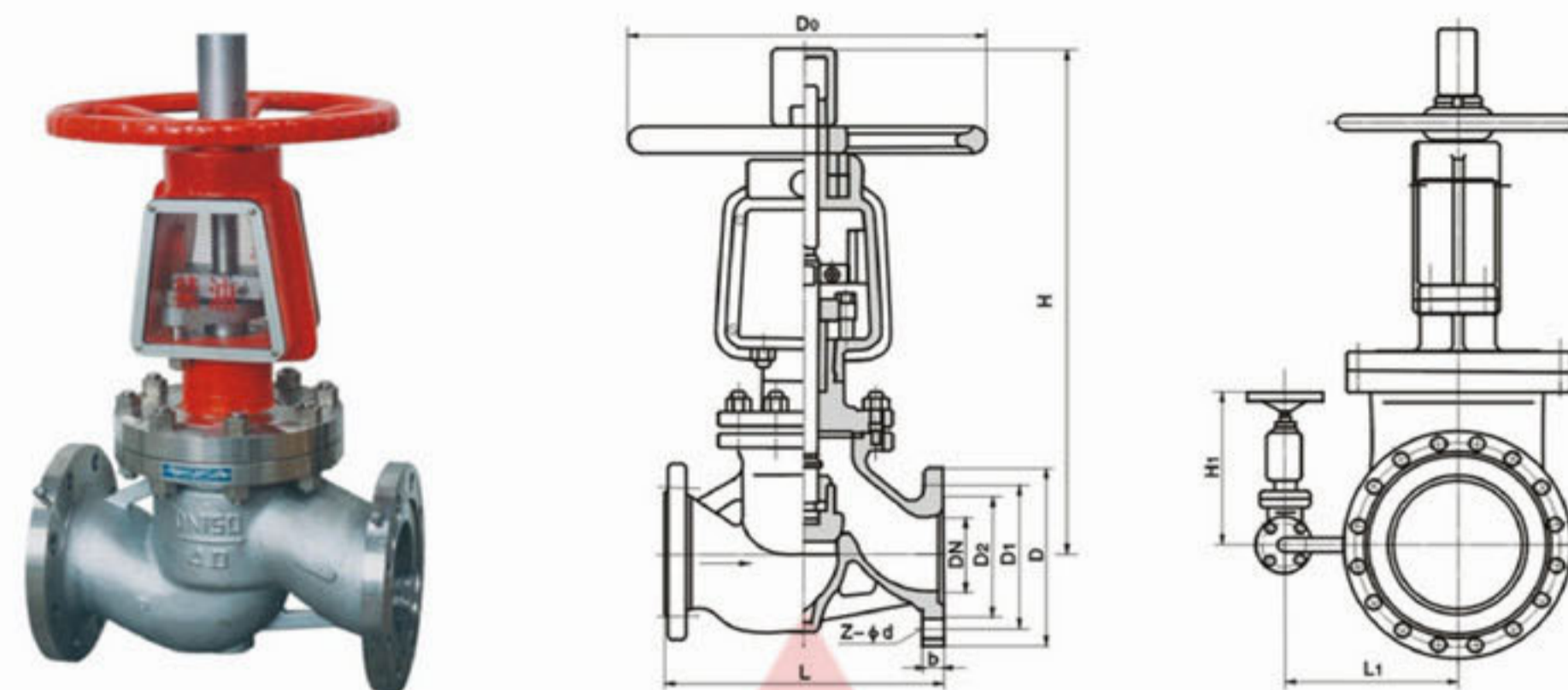

主要外形和连接尺寸 Main External and Connection Dimension

单位Unit:mm

公称通径 DN	主要外形尺寸和连接尺寸 (mm) Main external and connecting dimensions										WT (Kg)	
	L	D	D1	D2	D6	b	Z-φd	D0	H	H1		L1
YJ41W-40P YJ41W-40T												
15	130	95	65	45	40	16	4-14	100	202	-	-	5
20	150	105	75	55	51	16	4-14	100	225	-	-	6.5
25	160	115	85	65	58	16	4-14	125	236	-	-	7
32	190	135	100	78	66	18	4-18	180	312	-	-	13.5
40	200	145	110	85	76	18	4-18	160	328	-	-	16
50	230	160	125	100	88	20	4-18	320	450	-	-	32
65	290	180	145	120	110	22	8-18	360	530	-	-	45
80	310	195	160	135	121	22	8-18	400	560	-	-	60
100	350	230	190	160	150	24	8-23	450	618	-	-	80
125	400	270	220	188	176	28	8-25	450	675	-	-	105
150	480	300	250	218	204	30	8-25	560	743	-	-	134
200	600	375	320	282	260	38	12-30	640	850	-	-	266
250	650	445	385	345	313	42	12-34	720	975	380	340	491
300	750	510	450	408	364	46	16-34	800	1115	415	340	705
400	950	655	585	535	474	58	16-41	900	1425	465	340	1234



### 氟衬里截止阀

Teflon-lining Globe Valves Class300 Class400 WJs45Y、WJs545Y、WJs945Y

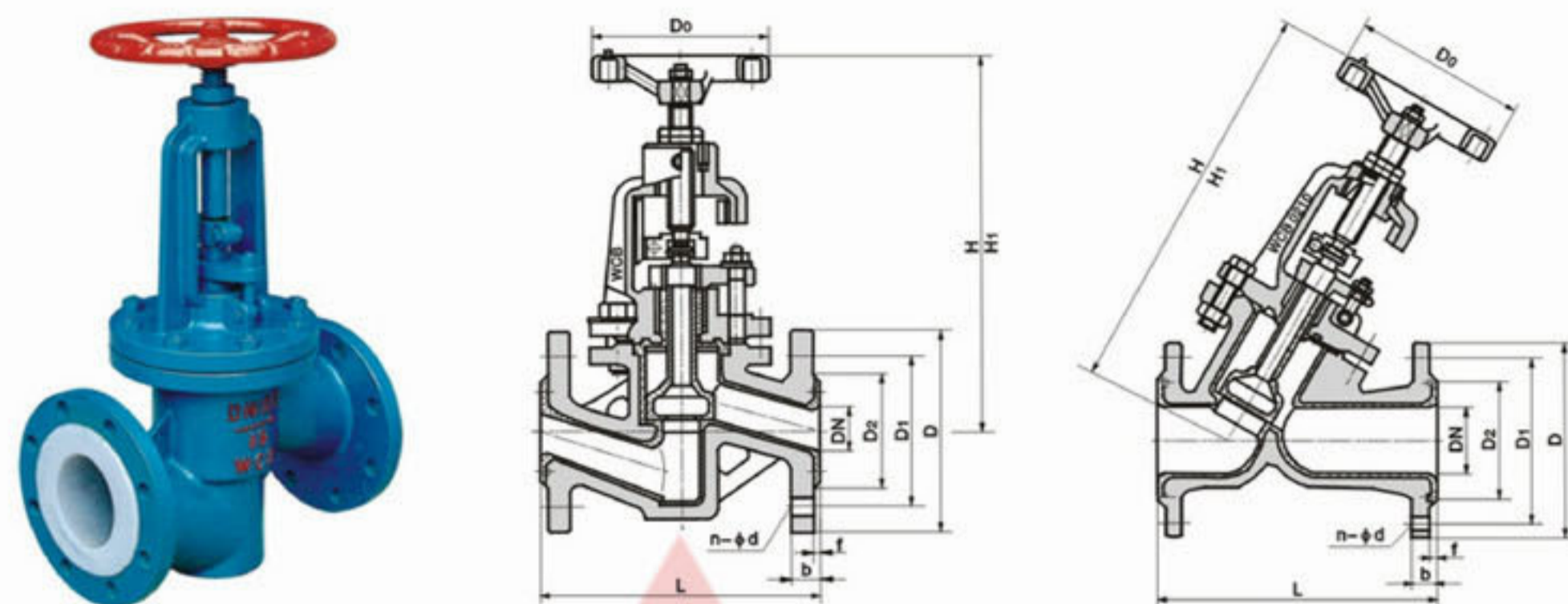

#### 执行标准 Administer Standard

设计规范 Design Spec	结构长度 Face to Face	连接法兰 Flange Dnd	试验与检验 Test & Check	产品标识 Marking	供货规范 Supply
GB/T 12233 (GB/T 12235)	GB/T 12221	JB/T 78; JB/ 79	GB/T13927	GB/T12220	JB/T 7928

#### 性能规范 Property and Specification

衬里/阀座 Lining/seat	代号 Code	适用温度℃ Suitbale Temperature℃	适用介质 Suitble medium
PTFE(F4)	F4	≤180	除熔融碱金属，元素氟外的各种浓度的酸、碱、盐、王水、有机酸等强腐蚀性介质。 All kinds of acid, alkali, salt, apuaregia, organic acid etc strong corrosive medium except molten alkali metals and element fluorin.
PCTFE(F3)	F3	≤120	
PFE(F46)	F46	≤150	
PFA(可溶性F4)	FA	≤180	
PVD(F2)	F2	≤100	
RPTFE(RF4)	FR4	≤180	

#### 主要零部件材料 Main Part Material

零件名称 Part Name	铸钢 Cast steel	不锈钢耐铸钢 Stainless acid resistant cast steel		超低碳不锈钢耐铸钢 Super-low -stainless acid resistant cast steel	
	C	P	R	PL	RL
阀体/阀盖 Body/Cover	WCB	CF8	CF8M	CF3	CF3M
阀瓣/阀杆 Disc/stem	2Cr13	1Cr18Ni19	1Cr18Ni12Mo2Ti	00Cr18Ni10	00Cr17Ni14Mo2
衬里阀座 Lining/seat	PTFE(f4)、PCTFE(F3)、FEP(F46)、PFA(可溶性F4)				
填料压盖 Packing cocer	WCB	CF8	CF8M	CF3	CF3M
填料 Packing	PTFE(F4)	PTFE(F4)		PTFE(F4)	
活结螺栓 Eyelet bolt	35	1Cr17Ni2		1Cr17Ni2	
阀杆螺母 Stem nut	ZCuAl10Fe3	ZCuAl10Fe3		ZCuAl10Fe3	
紧细螺栓 Clamp bolt	35	1Cr17Ni2		1Cr18Ni9Ti	
螺母 nut	45	0Cr18Ni9		0Cr18Ni9	
手轮 Hand wheel	WCB	WCB		WCB	

### 氟衬里截止阀

Teflon-lining Globe Valves Class300 Class400 WJs45Y、WJs545Y、WJs945Y

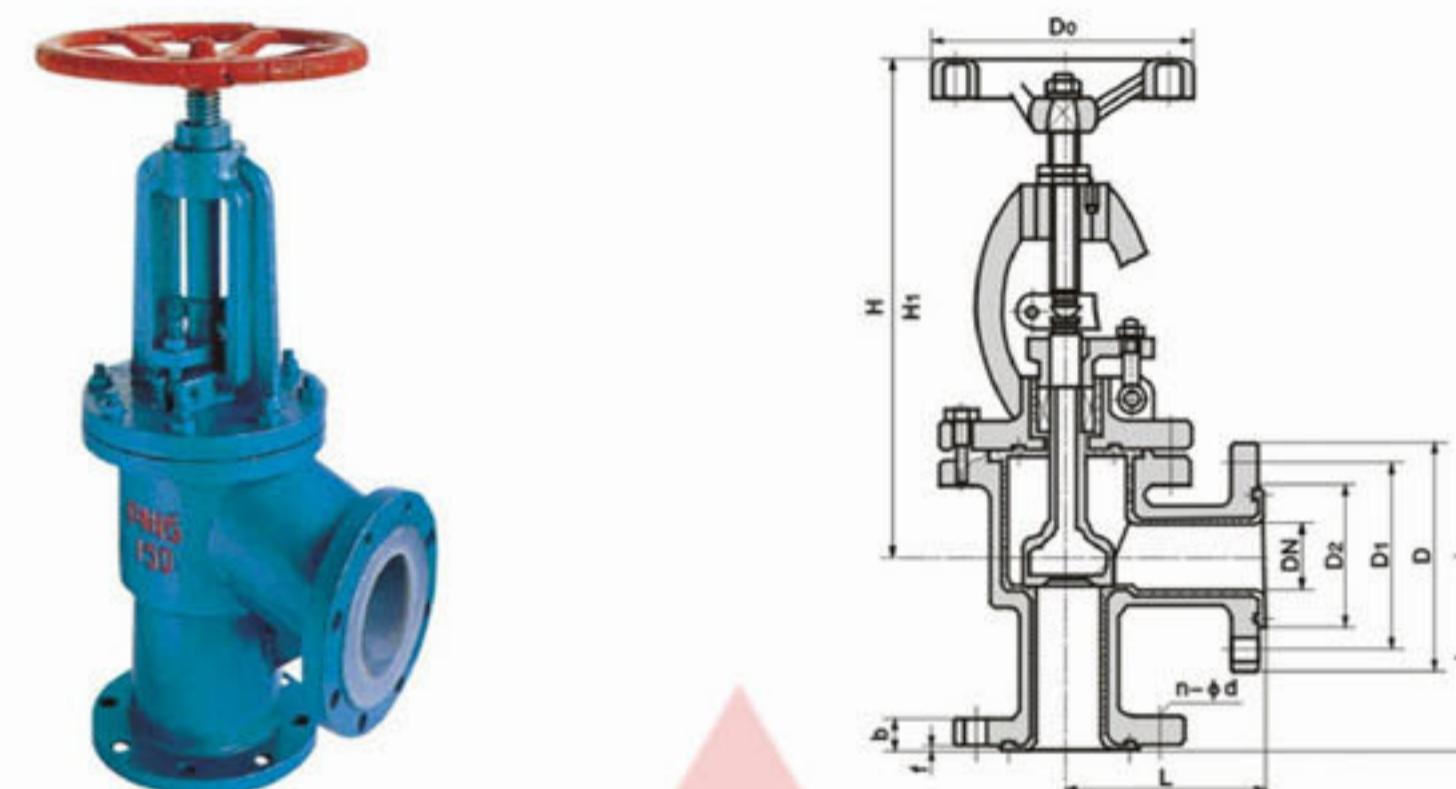

#### 执行标准 Administer Standard

设计规范 Design Spec	结构长度 Face to Face	连接法兰 Flange Dnd	试验与检验 Test & Check	产品标识 Marking	供货规范 Supply
GB/T 12233 (GB/T 12235)	GB/T 12221	JB/T 78; JB/ 79	GB/T13927	GB/T12220	JB/T 7928

#### 主要外形和连接尺寸 Main External and Connection Dimension

DN (mm)	NPS (inch)	L	D	D1	D2	f	b	n-φd	D0	H	H1	WT(kg)
PN1.0MPa												
15	1/2	65	95	65	45	2	14	4-φ14	100	240	265	7
20	3/4	75	105	75	55	2	16	4-φ14	100	245	270	7.5
25	1	80	115	85	65	2	16	4-φ14	120	250	275	8
32	1 1/4	95	135	100	78	2	18	4-φ18	120	260	290	12
40	1 1/2	100	145	110	85	3	18	4-φ18	140	90	325	14
50	2	115	160	125	100	3	20	4-φ18	140	300	335	19
65	2 1/2	145	180	145	125	3	20	4-φ18	160	355	400	27
80	3	155	195	160	135	3	22	4-φ18	160	400	450	42
100	4	175	215	180	155	3	22	8-φ18	180	455	495	50
125	5	200	245	210	185	3	24	8-φ18	180	530	560	64
150	6	240	280	240	210	3	24	8-φ23	240	605	650	85
200	8	275	335	295	265	3	26	8-φ23	240	650	770	105
250	10	325	390	350	320	3	28	12-φ23	280	680	800	135
300	12	375	440	400	368	4	28	12-φ23	280	710	835	155
PN1.6MPa												
15	1/2	65	95	65	45	2	14	4-φ14	100	240	265	7
20	3/4	75	105	75	55	2	16	4-φ14	100	245	270	7.5
25	1	80	115	85	65	2	16	4-φ14	120	250	275	8.8
32	1 1/4	95	135	100	78	2	18	4-φ18	140	260	290	12
40	1 1/2	100	145	110	85	3	18	4-φ18	140	290	325	14
50	2	115	160	125	100	3	20	4-φ18	160	300	335	19
65	2 1/2	145	180	145	120	3	20	4-φ18	180	355	400	27
80	3	155	195	160	135	3	22	8-φ18	240	400	450	42
100	4	175	215	180	155	3	24	8-φ18	240	455	495	50
125	5	200	245	210	165	3	26	8-φ18	280	530	560	64
150	6	240	280	240	210	3	28	8-φ23	320	605	650	85
200	8	275	335	295	265	3	30	8-φ23	360	650	770	155
PN2.5MPa												
15	1/2	65	95	65	45	2	16	4-φ14	120	245	270	7.5
20	3/4	75	105	75	55	2	16	4-φ14	120	250	275	8.5
25	1	80	115	85	65	2	16	4-φ14	140	260	290	11
32	1 1/4	95	135	100	78	2	18	4-φ18	140	290	325	13
40	1 1/2	100	145	110	85	3	18	4-φ18	160	300	335	18
50	2	115	160	125	100	3	20	4-φ18	180	355	400	31



### 节流截止放空阀

Discharge Globe Valves FJ41, FJL41, CJ41-1.6~16.0

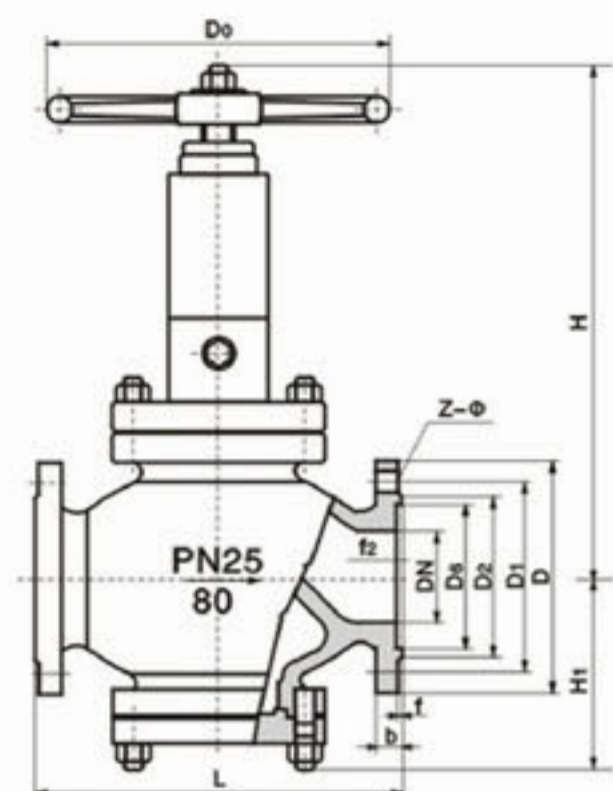

主要外形和连接尺寸 Main External and Connection Dimension

单位Unit:mm

公称压力 PN	DN(mm)	主要外形尺寸和连接尺寸 (mm) Main external and connecting dimensions							
		25	40	50	80	100	150	200	250
1.6MPa	L	216	230	230	310	350	480	600	730
	H	243	265	346	409	484	521	594	621
	H1	86	108	115	146	163	202	292	355
	D0	180	250	250	300	300	350	350	400
	WT(Kg)	17	24	27	52	60	125	165	285
2.5MPa	L	216	230	230	310	350	480	600	730
	H	243	265	346	409	433	521	594	621
	H1	86	108	115	146	163	202	292	355
	D0	180	250	250	300	300	350	350	400
	WT(Kg)	17	24	27	55	66	140	180	310
4.0MPa	L	216	230	230	310	350	480	600	730
	H	243	265	346	409	433	521	594	621
	H1	86	108	115	146	163	202	292	355
	D0	180	250	250	300	300	350	350	400
	WT(Kg)	20	29	32	67	80	168	215	372
6.4MPa	L	216	230	230	310	350	480	600	730
	H	243	265	346	409	433	521	594	621
	H1	86	108	115	146	163	202	292	355
	D0	180	250	250	300	300	350	350	400
	WT(Kg)	20	29	32	67	80	168	315	372
10.0MPa	L	230	260	300	380	430	559	660	787
	H	245	265	287	409	433	531	709	817
	H1	78	106	110	152	169	225	321	399
	D0	200	250	300	350	250	400	500	500
	WT(Kg)	29	42	55	95	120	240	310	530
16.0MPa	L	230	260	300	390	450			
	H	215	265	237	414	440			
	H1	78	105	110	155	175			
	D0	200	250	300	350	350			
	WT(Kg)	35	50	65	116	145			

### 不锈钢内螺纹截止阀

Stainless steel Inside screw Globe Valve

**特点:**

全通径流量  
 产品规格从1/2"到2"  
 工作压力:200PSI  
 内螺纹端可按BSPT、NPT、DIN2999制造

**Feature**

Full Bore  
 Size: 1/2" to 2"  
 Working Pressure: 200PSI  
 Female Threaded End: BSPT, NPT, DIN2999

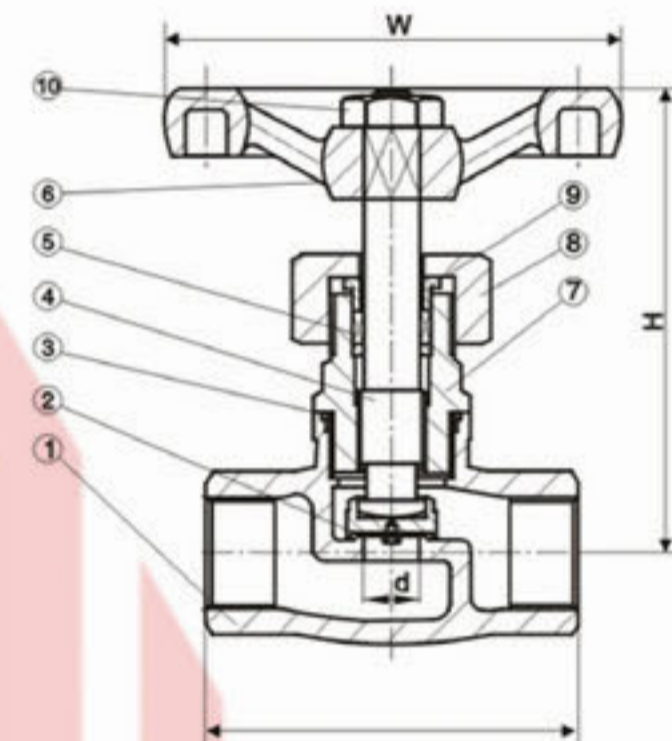

材料列表 Materiallist

No	部件名称 Part Name	材料 Material	
1	阀体 Body	CF8M	CF8
2	闸瓣 Disc	CF8M	CF8
3	密封圈 Seal Ring	SS316	SS316
4	阀杆 Stem	SS316	SS304
5	填料 PTFE	PTFE	
6	手轮 Handwheel	HT(C.R.)	
7	阀盖 Bonnet	CF8M	CF8
8	压盖螺母 Gland Nut	SS316	
9	填料压盖 Packing Gasket	SS316	
10	螺母 Nut	SS316	

尺寸列表 Dimension List

单位Unit:mm

NPS	d	H	L	W
1/2"	15	105	50	70
3/4"	20	108	60	70
1"	25	135	65	80
1-1/4"	32	145	75	80
1-1/2"	40	155	85	90
2"	50	185	95	100