

# 止回阀系列

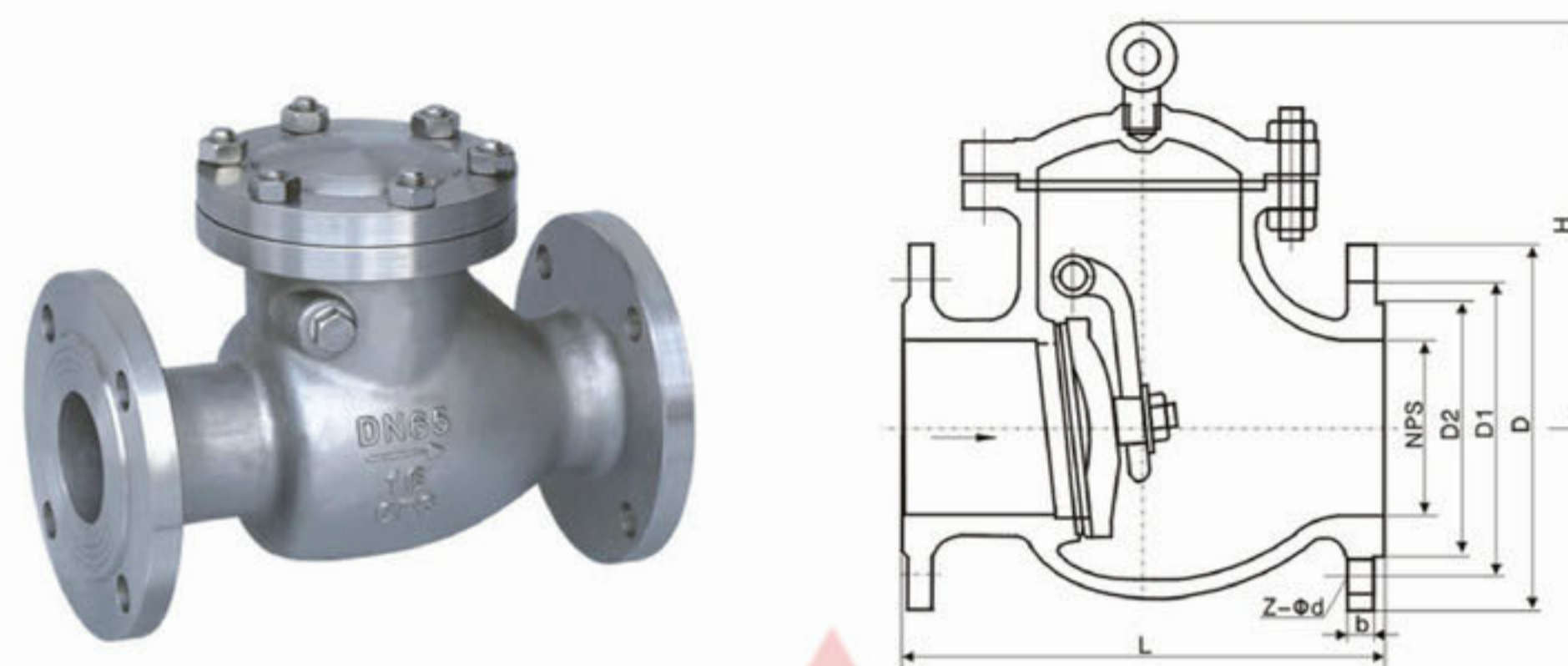

## 旋启式止回阀

Swing Check Valves H44H(Y)-16-25P/R/I



主要外形和连接尺寸 Main external and connection dimension

单位Unit: mm

公称 通径 DN	主要外形尺寸和连接尺寸 (mm) Main external and connecting dimensions							WT (Kg)
	L	D	D1	D2	b	Z-φd	H	
	H44H-16C H44W-16C H44W-16P H44W-16R H44W-16 I							
50	230	160	125	100	16	4-φ18	135	21
65	290	180	145	120	18	4-φ18	142	28
80	310	195	160	135	20	8-φ18	165	38
100	350	215	180	155	20	8-φ18	180	58
125	400	245	210	185	22	8-φ18	210	92
150	480	280	240	210	24	8-φ23	233	130
200	500	335	295	265	26	12-φ23	304	210
250	550	405	355	320	30	12-φ25	348	294
300	650	460	410	375	30	12-φ25	390	367
350	750	520	470	435	34	16-φ25	430	410
400	850	580	525	485	36	16-φ30	468	461
450	950	640	585	545	40	20-φ30	523	570
500	1025	705	650	608	44	20-φ34	525	850
	H44W-25 H44W-25 H44W-25P H44W-25R H44W-25 I							
50	230	160	125	100	20	4-φ18	160	22
65	290	180	145	120	22	8-φ18	175	29
80	310	195	160	135	22	8-φ18	185	38
100	350	230	190	160	24	8-φ23	220	61
125	400	270	220	188	28	8-φ25	248	96
150	480	300	250	218	30	8-φ25	276	132
200	550	360	310	278	34	12-φ25	350	213
250	650	425	370	332	36	12-φ30	410	297
300	750	485	430	390	40	16-φ30	430	372
350	850	550	490	448	44	16-φ34	518	415
400	950	610	550	505	48	16-φ34	560	480
450	1025	660	600	555	50	20-φ34	582	610
500	1150	730	660	610	52	20-φ41	618	920



### 旋启式止回阀

Swirl Check Valves H44H(Y)-40~64P/R/I

主要外形和连接尺寸 Main external and connection dimension

单位Unit: mm

公称 口径 DN	主要外形尺寸和连接尺寸 (mm) Main external and connecting dimensions										WT (Kg)
	L	D	D1	D2	D6	b	f	f2	Z-φd	H	
	H44H-40 H44W-40 H44W-40P H44W-40R H44W-40I										
50	230	160	125	100	88	20	3	4	4-φ18	169	22
65	290	180	145	120	110	22	3	4	8-φ18	173	29
80	310	195	160	135	121	22	3	4	8-φ18	185	38
100	350	230	190	160	150	24	3	4.5	8-φ23	220	61
125	400	270	220	188	176	28	3	4.5	8-φ25	248	96
150	480	300	250	218	204	30	3	4.5	8-φ25	270	132
200	550	375	320	282	260	38	3	4.5	12-φ30	342	213
250	650	445	385	345	313	42	3	4.5	12-φ34	401	297
300	750	510	450	408	364	46	4	4.5	16-φ34	423	372
350	850	570	510	465	422	52	4	5	16-φ34	455	415
400	950	655	585	535	474	58	4	5	16-φ41	510	480

主要外形和连接尺寸 Main external and connection dimension

单位Unit: mm

公称 口径 DN	主要外形尺寸和连接尺寸 (mm) Main external and connecting dimensions										WT (Kg)
	L	D	D1	D2	D6	b	f	f2	Z-φd	H	
	H44H-64 H44W-64 H44W-64P H44W-64R H44W-64I										
50	300	175	135	105	88	26	3	4	4-φ23	177	27
65	340	200	160	130	110	28	3	4	8-φ23	197	37
80	380	210	170	140	121	30	3	4	8-φ23	212	57
100	430	250	200	168	150	32	3	4.5	8-φ25	248	89
125	500	295	240	202	176	36	3	4.5	8-φ30	296	135
150	550	340	280	240	204	38	3	4.5	8-φ34	330	184
200	650	405	345	300	260	44	3	4.5	12-φ34	385	266
250	775	470	400	352	313	48	3	4.5	12-φ41	445	396
300	900	530	460	412	364	54	4	4.5	16-φ41	474	643
350	1025	595	525	475	422	60	4	5	16-φ41	514	815
400	1150	670	585	525	474	66	4	5	16-φ48	616	1234

### 升降式止回阀

Lift Check Valves H41H(Y)-16~25C/P/R/I

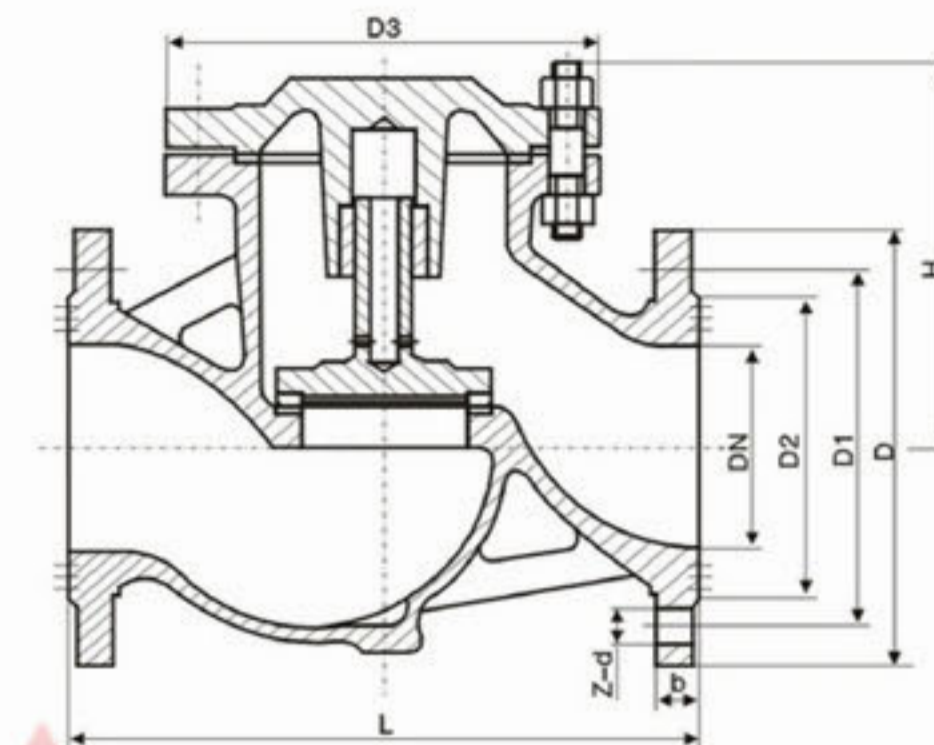

主要外形和连接尺寸 Main external and connection dimension

单位Unit: mm

公称 口径 DN	主要外形尺寸和连接尺寸 (mm) Main external and connecting dimensions							WT (Kg)
	L	D	D1	D2	b	Z-φd	H	
	H41H-16C H41W-16C H41W-16P H41W-16R H41W-16I							
15	130	95	65	45	14	4-φ14	77	3
20	150	105	75	55	14	4-φ14	77	4
25	160	115	85	65	14	4-φ14	80	5
32	180	135	100	78	16	4-φ18	85	7
40	200	145	110	85	16	4-φ18	95	9
50	230	160	125	100	16	4-φ18	105	10
65	290	180	145	120	18	4-φ18	120	20
80	310	195	160	135	20	8-φ18	130	30
100	350	215	180	155	20	8-φ18	140	39
125	400	245	210	185	22	8-φ18	155	50
150	480	280	240	210	24	8-φ23	180	70
200	600	335	295	265	26	12-φ23	215	161
250	730	405	355	320	30	12-φ25	260	251
300	850	460	410	375	34	12-φ25	315	395
	H41H-25 H41W-25 H41W-25P H41W-25R H41W-25I							
15	130	95	65	45	16	4-φ14	100	3.4
20	150	105	75	55	16	4-φ14	105	5
25	160	115	85	65	16	4-φ14	120	5.7
32	180	135	100	78	18	4-φ18	130	9.1
40	200	145	110	85	18	4-φ18	135	11.8
50	230	160	125	100	20	4-φ18	149	14.4
65	290	180	145	120	22	8-φ18	160	23
80	310	195	160	135	22	8-φ18	169	30
100	350	230	190	160	24	8-φ23	194	44
125	400	270	220	180	28	8-φ25	222	65
150	480	300	250	218	30	8-φ25	255	99
200	600	360	310	278	34	12-φ25	305	190
250	730	425	370	332	36	12-φ30	355	315
300	850	485	430	390	40	16-φ30	410	450



### 升降式止回阀

Lift Check Valves H41H(Y)-40-64P/R/I

#### 主要外形和连接尺寸 Main external and connection dimension

单位Unit: mm

公称 口径 DN	主要外形尺寸和连接尺寸 (mm) Main external and connecting dimensions								WT (Kg)
	L	D	D1	D2	D6	b	Z-φd	H	
	H41H-40 H41W-40 H41W-40P H41W-40R H41W-40I								
15	130	95	65	45	40	16	4-φ14	100	4
20	150	105	75	55	51	16	4-φ14	105	5.5
25	160	115	85	65	58	16	4-φ14	120	6
32	180	135	100	78	66	18	4-φ18	130	12
40	200	145	110	85	76	18	4-φ18	135	14
50	230	160	125	100	88	20	4-φ18	149	18
65	290	180	145	120	110	22	8-φ18	160	27
80	310	195	160	135	121	22	8-φ18	169	36
100	350	230	190	160	150	24	8-φ23	194	50
125	400	270	220	188	176	28	8-φ25	225	75
150	480	300	250	218	204	30	8-φ25	255	119
200	600	375	320	282	260	38	12-φ30	305	217
250	730	445	385	345	313	42	12-φ34	360	365
300	850	510	450	408	364	46	12-φ34	415	310

#### 主要外形和连接尺寸 Main external and connection dimension

单位Unit: mm

公称 口径 DN	主要外形尺寸和连接尺寸 (mm) Main external and connecting dimensions								WT (Kg)
	L	D	D1	D2	D6	b	Z-φd	H	
	H41H-64 H41W-64 H41W-64P H41W-64R H41W-64I								
15	210	105	75	55	40	18	4-φ14	100	7
20	230	125	90	68	51	20	4-φ18	110	11
25	230	135	100	78	58	22	4-φ18	125	13
32	260	150	110	82	66	24	4-φ23	140	14
40	260	165	125	95	76	24	4-φ23	168	20
50	300	175	135	105	88	26	4-φ23	170	23
65	340	200	160	130	110	28	8-φ23	188	37
80	380	210	170	140	121	30	8-φ23	205	46
100	430	250	200	168	150	32	8-φ25	230	68
125	500	295	240	202	176	36	8-φ30	230	89
150	550	340	280	240	204	38	8-φ34	265	131
200	650	405	345	300	260	44	12-φ34	310	235

### 美标止回阀

API Forging Check Valves

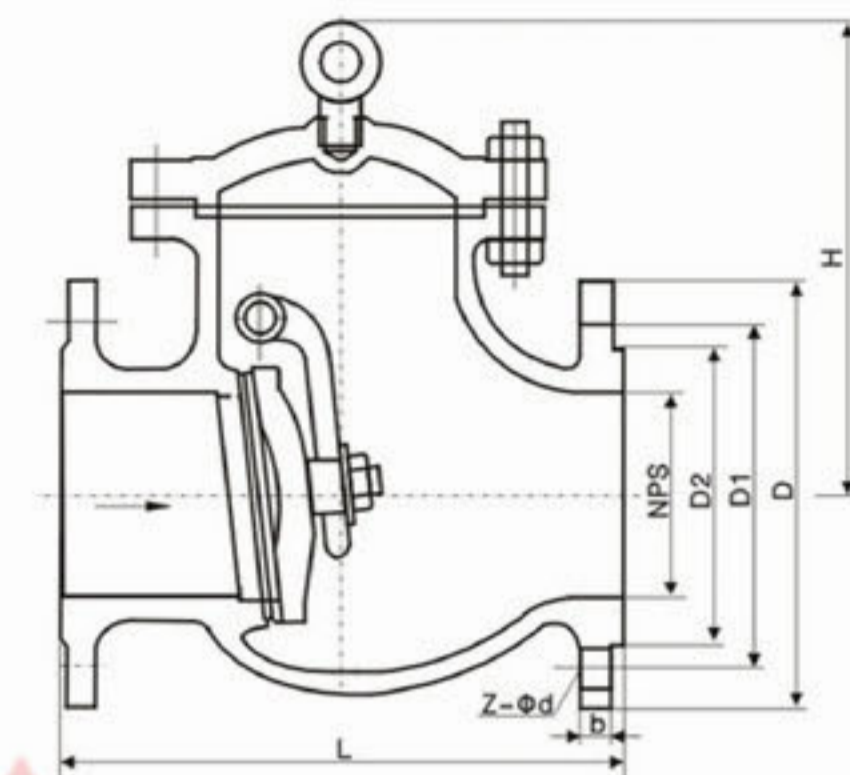

#### 产品执行标准 Production enforce standard

类型TYPE	设计与制造 Desing And Manufacture	结构长度 Face to Face/ End to end	法兰尺寸 Flange Dimension	压力-温度 Pressure Temperature Lating	试验-检验 Inspection and test
旋启式止回阀Swing Check valve	ANSIB16.34	ANSIB16.10	ANSIB16.15	ANSIB16.34	API598
升降式止回阀Lift Check valve	BS1868				

#### 产品性能规范 Chief property and spefification

公称压力(Lb)Nominal Pressore	150	300	600	900	
强度试验 Shell test	Mpa	3.1	7.8	15.3	23.1
	Lbf/in <sup>2</sup>	450	1125	2225	3350
水密封试验 Water seal test	Mpa	2.2	5.6	11.2	16.8
	Lbf/in <sup>2</sup>	315	815	1630	2440
气密封试验 Air seal test	Mpa	0.5~0.7			
	Lbf/in <sup>2</sup>	60~100			

#### 主要零件材料及性能 Main part materials property

体、盖、瓣、摇杆、导向套 Body Cover DiskHingeside way bush	销轴 Hinge pin	垫片 Sealing shim	密封面 Sealing Face	工作温度(°C) Working temperature	适用介质 Suitable medium
WCB	2Cr13	增强柔性石墨 1Cr13/柔性石墨 不锈钢/耐酸石棉 PTFE 齿型垫片 Enhanced Flexible graphite	13Cr STL 本体材料 PTFE 尼龙 With bodymater rial Nylon	≤425	水、蒸汽、油品 Water steam oil
WC1				≤450	
WC6				≤540	
WC9				≤570	
C5 C12				≤550	
CF8	304	Tooth profile gashker	bodymater rial Nylon	≤200 非腐蚀性介质	硝酸类、醋酸类、 强氧化介质、 尿素 Petroleum products Nitric acid Acetic acid
CF3	316				
CF8M	304L				
CF3M	316L				



### 磅级止回阀

ANSI Check Valves Class 150Lb/300Lb/600Lb

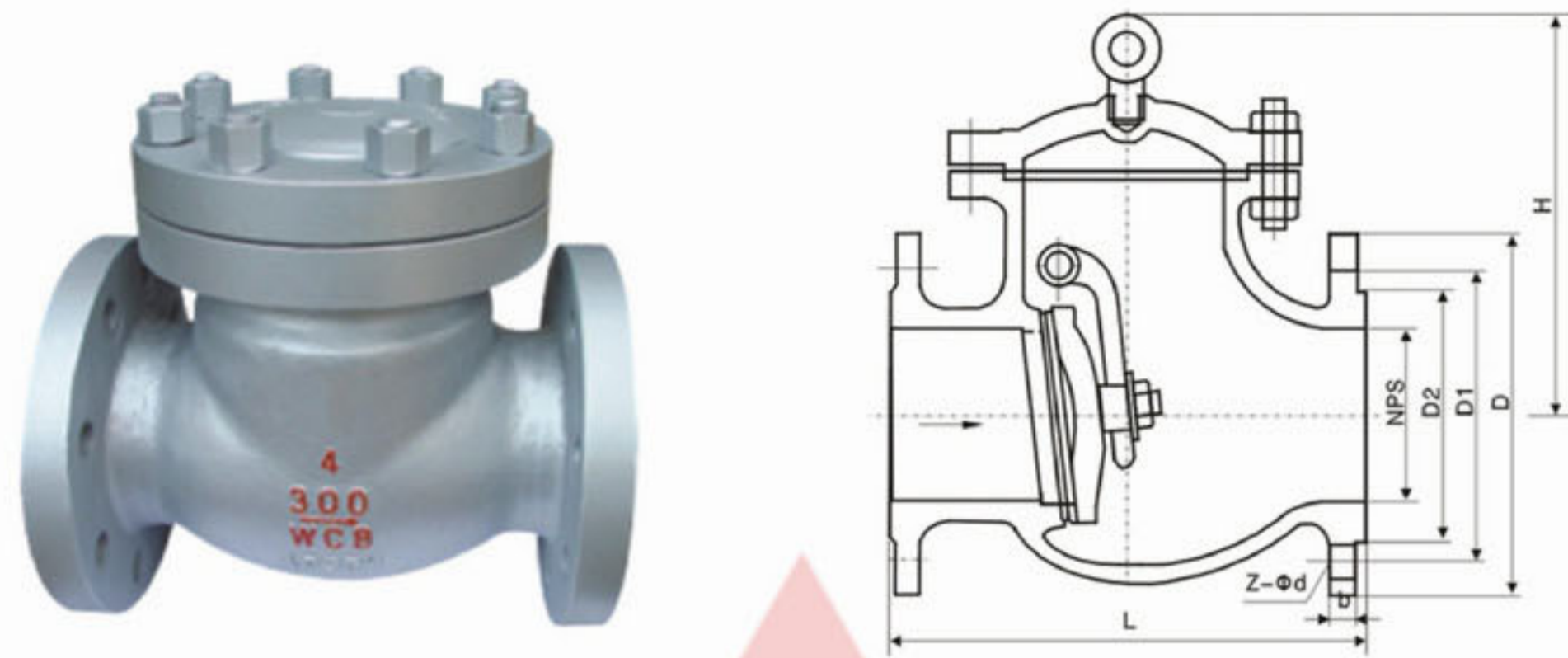

主要外形和连接尺寸 Main external and connection dimension

单位Unit: mm

Class	NPS	DN	L	D	D1	D2	b	Z-φd	H	WT (Kg)
	in	mm								
150Lb	2"	50	203	157	120.7	92	19.50	4-φ19	161	17
	2 1/2"	65	216	178	139.7	105	22.5	4-φ19	180	23
	3"	80	241	190.5	152.4	127	24	4-φ19	190	33
	4"	100	292	229	190.50	157.2	24	8-φ19	220	44
	6"	150	356	279	241.5	216	25.5	8-φ22.5	257	78
	8"	200	495	343	298.5	270	29	8-φ22.5	292	137
	10"	250	622	406	362	324	30.5	12-φ25	350	207
	12"	300	698	483	432	381	32	12-φ25	398	279
	14"	350	787	533	476.8	413	35	12-φ29	445	387
	16"	400	864	597	539.8	470	37	16-φ29	490	446
	18"	450	978	635	577.8	533	40	16-φ32	520	621
	20"	500	978	698	635	584	43	20-φ32	546	770
24"	600	1295	813	749.3	692	48	20-φ35	880	970	
300Lb	2"	50	267	165	127	92	22.5	8-φ19	179.5	20
	2 1/2"	65	292	190	150	105	25	8-φ22	190	24
	3"	80	318	210	168	127	29.0	8-φ22.5	212.4	40
	4"	100	356	254	200	157	32.0	8-φ22.5	246	51
	6"	150	445	317.5	269.7	216	37.0	12-φ22.5	292	90
	8"	200	533	381	330	270	41.5	12-φ25.5	328	175
	10"	250	622	444.5	387	324	48.0	16-φ28.5	378.6	210
	12"	300	711	521	451	381	51.0	16-φ32	420	286
	14"	350	838	584	514	54	54	20-φ32	470	400
	16"	400	864	648	572	57	57	20-φ35	530	550
	18"	450	978	711	629	60	60	24-φ35	584	700
	20"	500	1016	775	686	64	64	24-φ35	610	860
24"	600	1346	914	813	70	70	24-φ41	860	1931	
600Lb	2"	50	292	165	127	92	25	8-φ19	203	34
	2 1/2"	65	330	190	150	105	29	8-φ22	229	45
	3"	80	356	210	168	127	32	8-φ22	235	63
	4"	100	432	273	216	157	38	8-φ25	286	114
	6"	150	559	356	292	216	48	8-φ29	330	207
	8"	200	660	419	349	270	56	12-φ29	381	387
	10"	250	787	508	432	324	64	12-φ32	457	580
	12"	300	838	559	489	381	67	16-φ35	584	778
	14"	350	889	603	527	413	70	20-φ38	635	9869
	16"	400	991	686	603	470	76	20-φ41	684	1380

### 日标不锈钢旋启式止回阀 JIS Stainless Steel Swing Check Valve

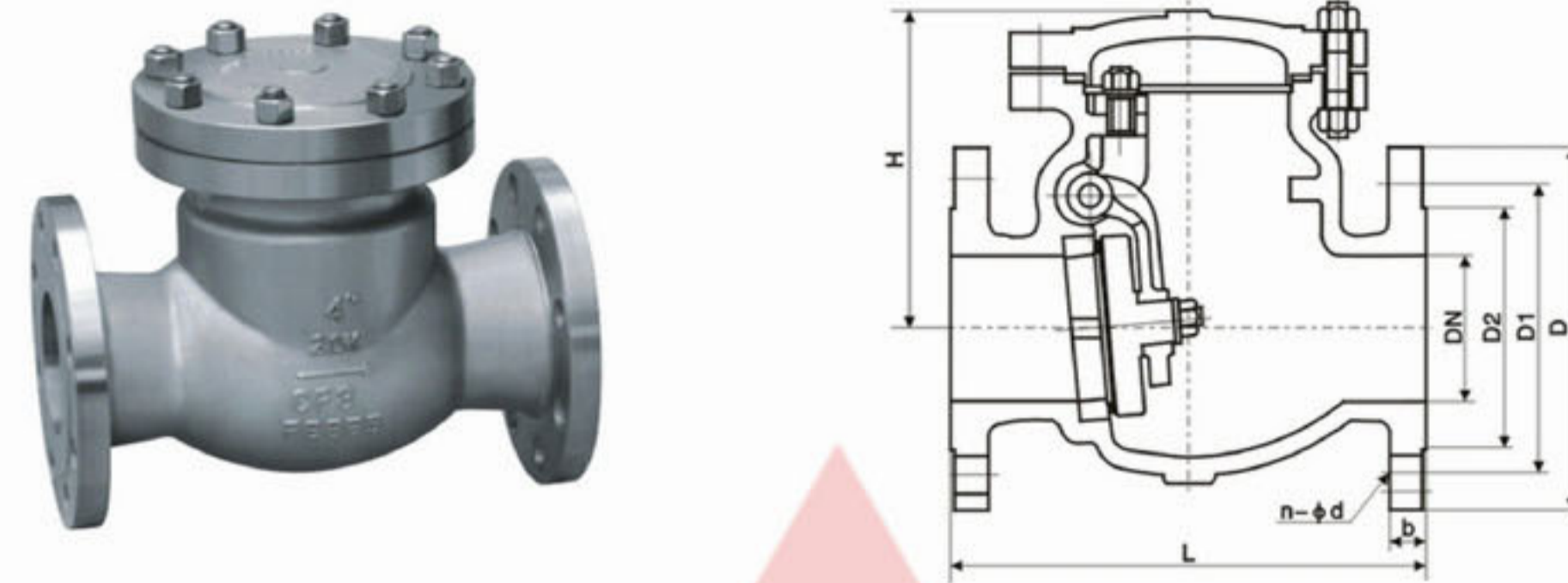

执行标准 Administer Standard

设计与制造	结构长度	法兰尺寸	压力-温度	试验-检验
JIS B2074 B2084	JIS B2002	JIS B2212 B2214	JIS B2074 B2084	JIS B2003

规格主要尺寸 Size Main Dimensions

DN		10K						
mm	in	L	D	D1	D2	b	n-φd	H
50	2"	203	155	120	100	16	4-φ19	165
65	2 1/2"	216	175	140	120	18	4-φ19	175
80	3"	241	185	150	130	18	8-φ19	190
100	4"	292	210	175	155	18	8-φ19	215
125	5"	330	250	210	185	20	8-φ23	240
150	6"	356	280	240	215	22	8-φ23	265
200	8"	495	330	290	265	22	12-φ23	320
250	10"	622	400	355	325	24	12-φ23	365
300	12"	698	445	400	370	24	16-φ25	415
		20k						
50	2"	261	155	120	100	22	8-φ19	190
65	2 1/2"	292	175	140	120	24	8-φ19	205
80	3"	318	200	160	135	26	8-φ23	220
100	4"	356	225	185	160	28	8-φ23	245
125	5"	400	270	225	195	30	8-φ25	270
150	6"	444	305	261	230	32	12-φ25	295
200	8"	533	350	305	275	34	12-φ25	330
250	10"	622	430	380	345	38	12-φ27	420
300	12"	711	480	430	395	40	16-φ27	480
350	14"	838	540	480	440	40	16-φ33	535
400	16"	864	605	540	495	46	16-φ33	585
450	18"	978	675	605	560	48	20-φ33	615



### 电站止回阀

Power-station check valve H64Y-1500Lb~2500Lb

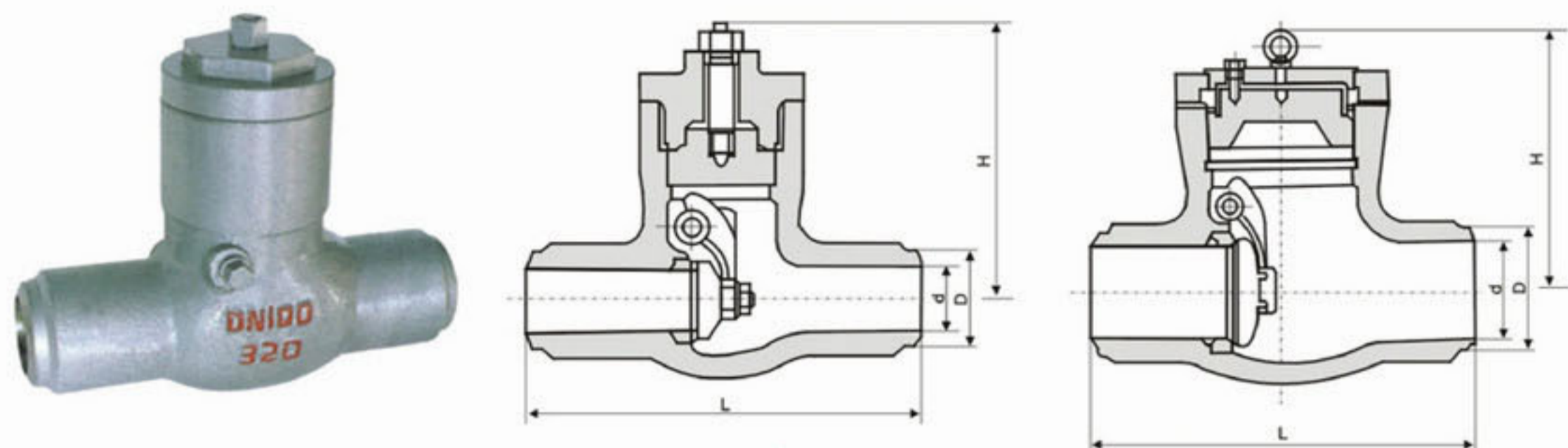

主要外形和链接尺寸 Main external and connectin dimensions

单位Unit:mm

公称通径DN	mm	L	D	H	WT (Kg)
H64Y-1500Lb					
2 1/2"	65	254	56	250	35
3"	80	305	64	300	45
4"	100	406	84	350	80
5"	125	483	100	425	115
6"	150	559	126	400	180
8"	200	711	158	490	270
10"	250	864	200	540	430
12"	300	991	250	650	630
14"	350	1067	280	710	810

主要外形和链接尺寸 Main external and connectin dimensions

单位Unit:mm

公称通径DN	mm	L	D	H	WT (Kg)
H64Y-2000Lb					
2 1/2"	65	330	50	240	40
3"	80	368	60	305	60
4"	100	457	80	315	95
5"	125	533	88	380	110
6"	150	610	118	425	160
8"	200	762	146	480	330
10"	250	914	180	570	540
12"	300	1041	222	570	800
14"	350	1118	254	680	930

主要外形和链接尺寸 Main external and connectin dimensions

单位Unit:mm

公称通径DN	mm	L	D	H	WT (Kg)
H64Y-2500Lb					
3"	80	368	56	270	70
4"	100	457	75	385	110
5"	125	533	86	410	130
6"	150	610	104	455	180
8"	200	762	136	555	380
10"	250	914	162	615	730
12"	300	1041	210	715	1120
14"	350	1118	234	790	1495

### 锻钢止回阀

Forged Check Valves H11H(Y)41/61-16~160 H11Y/41/61-800Lb

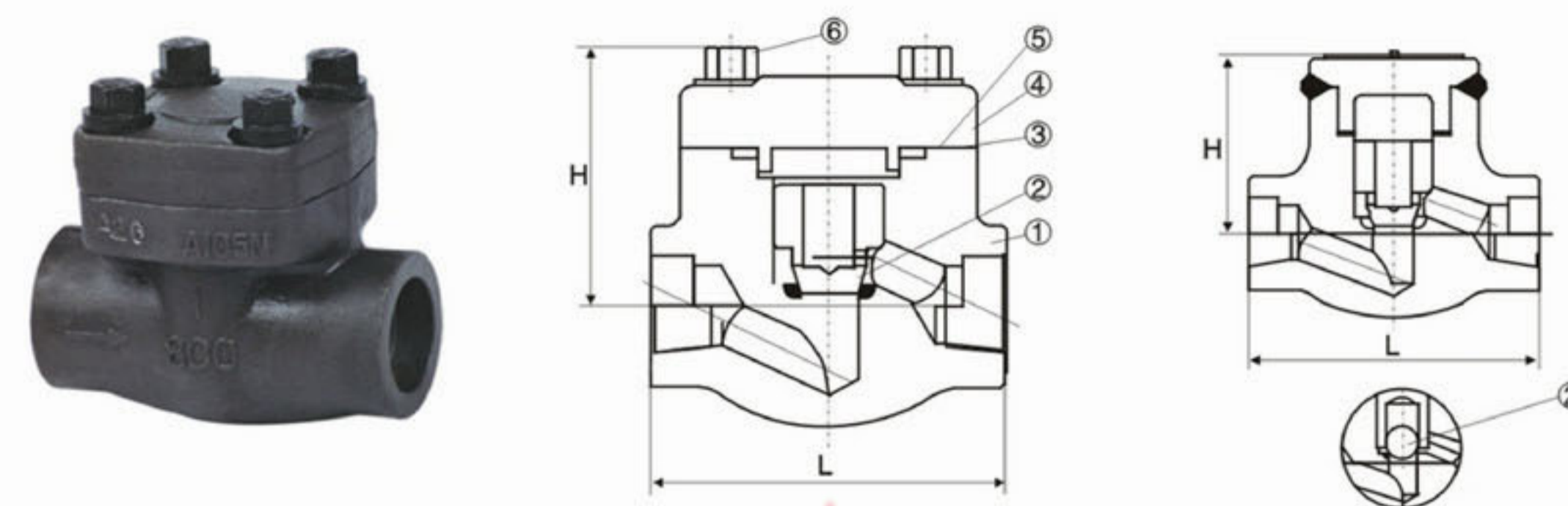

主要外形和连接尺寸 Main External and Connection Dimension

单位Unit:mm

公称通径 DN	主要外形尺寸和连接尺寸 (mm) Main external and connecting dimensions							WT(Kg)	
	L	d	S	L1	T	L2	H	FLD.	SC/SW
H41H-16C H41H-25 H41H-40 H11H-16C H11H-25 H11H-40 H61H-16C H61H-25 H61H-40 H41H-64 H41Y-100 H41Y-160 H11H-64 H11Y-100 H11Y-160 H61H-64 H61Y-100 H61Y-160 H41Y-1800Lb H11Y-800Lb H61Y-800Lb H61Y-800Lb									
15	90	13	22.5	10	1/2	15	61	3.0	1.5
20	100	18	28.5	11	3/4	17	78	4.0	3.0
25	120	23	34.5	12	1	19	84	5.8	3.9
32	140	28	43	14	1 1/4	21	103	8.5	5.6
40	170	36	49	15	1 1/2	21	118	10.1	8.9
50	200	45	61	16	2	25	132	15.6	12.5



### 消声止回阀

Noise elimination check valves HC41X-16

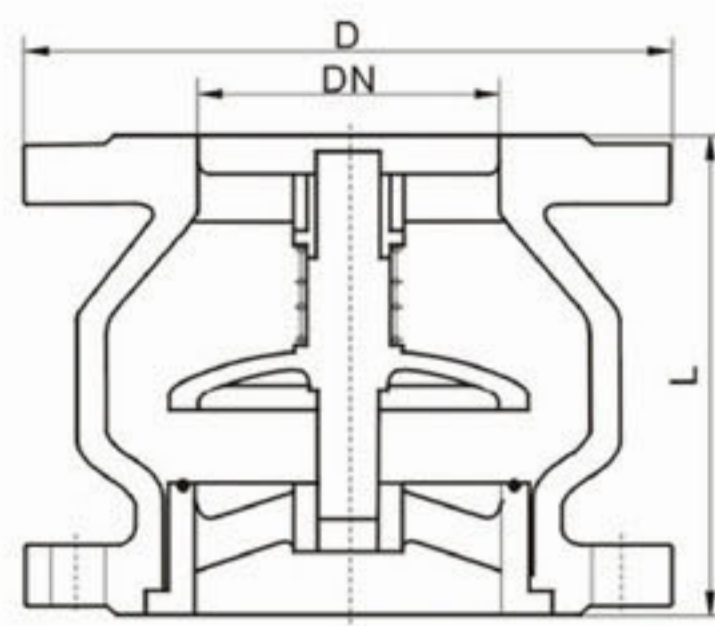

#### 性能规范 Technical data

公称口径 Nominal Diameter(DN)	50-200	
公称压力 PN(MPa) Nominal pressure	16	10
动作压力 Action Pressure	≥0.12MPa	
适用介质 Suitable medium	水 Water	
适用温度°C Suitable temperature	≥100	

#### 主要零部件材料 Material of Main Parts

名称 Name	阀体 Valve body	阀板 valve board	阀杆 Valve pole	导向支架 Guiding holder	缓冲环 Slow a ring down
材料 Material	铸铁 Casting	铸铁嵌 Casting Rubber is enclosed	铸青铜 Bronze	铸铁、铜环 Castiron, copper are encircled by	铸铁、铜环 Castiron, copper are encircled by

一可根据用户需求生产铸青铜，不锈钢阀体的止回阀。  
 One may produce Zhu bronze according to consumer need, stainless steel valve body non-return valve.

#### 外形尺寸及重量 Overall & Connection Dimensions & Weight

公称压力 PN(MPa) Nominal pressure	公称口径 DN(mm) Nominal diameter	尺寸 Size (mm)				
		L	D	K	b	Z-φd
1.0	40	124	145	110	18	4-φ18
	50	125	165	125	20	4-φ18
	65	134	185	145	20	4-φ18
	80	153	200	160	22	8-φ18
	100	161	220	180	24	8-φ18
	125	188	250	210	26	8-φ18
	150	220	285	240	26	8-φ18
	200	252	340	295	28	8-φ18
	250	270	395	350	28	12-φ22
	300	286	445	400	28	12-φ22
	350	380	505	460	30	16-φ22
	400	405	565	515	32	16-φ26
450	430	615	565	32	20-φ26	
500	450	670	620	34	20-φ26	
600	510	780	725	36	20-φ26	
1.6	40	124	145	110	18	4-φ18
	50	125	165	125	20	4-φ18
	65	134	185	145	20	4-φ18
	80	153	200	160	22	8-φ18
	100	161	220	180	24	8-φ18
	125	188	250	210	26	8-φ18
	150	220	285	240	26	8-φ18
	200	252	340	295	30	12-φ22
	250	270	405	355	32	12-φ26
	300	286	460	410	32	12-φ26
	350	380	520	470	36	16-φ26
	400	405	580	525	38	16-φ30
450	430	640	585	40	20-φ30	
500	450	710	650	42	20-φ33	
600	510	840	770	48	20-φ36	

### 微阻缓闭止回阀

Low Resistance dashpot check valves HH44T/44X/44H/44T-10~25(C)

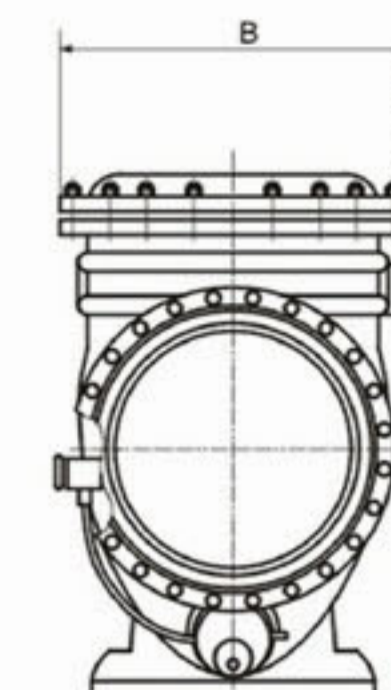
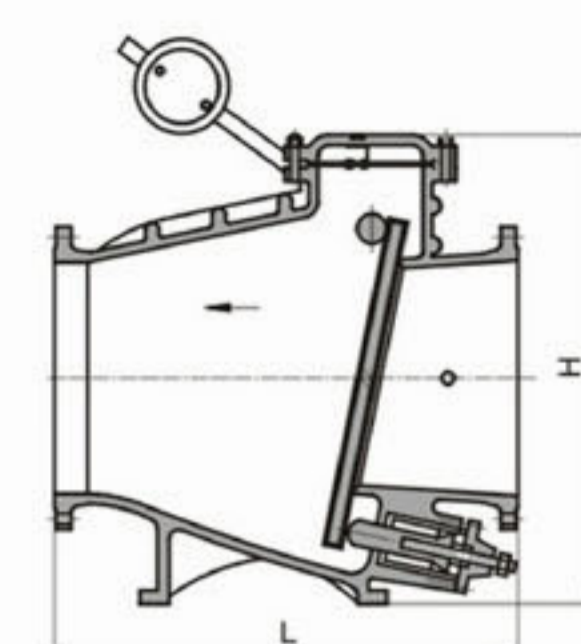

#### 主要外形和连接尺寸 Main External and Connection Dimension

单位 Unit: mm

公称口径 DN	主要外形尺寸和连接尺寸 (mm) Main external and connecting dimensions			WT(Kg)
	L	W	H	
HH44T-10 HH44X-10 HH44H-10C HH44T-16 HH44X-16C HH44H-16C HH44T-25 HH44X-25 HH44H-25				
50	230	270	300	58
65	290	290	320	70
80	310	300	354	83
100	350	320	350	120
125	400	340	380	146
150	480	410	500	175
200	500	450	580	205
250	600	550	670	427
300	700	580	730	597
350	800	630	820	800
400	900	700	920	1168
450	1000	800	950	1460
500	1100	900	1100	1795
600	1300	990	1200	2125
700	1400	1120	1550	2668
800	1500	1300	1700	3050



### H41M立卧两用静音止回阀

Stands lie dual-purpose loudspeaker mute check valves

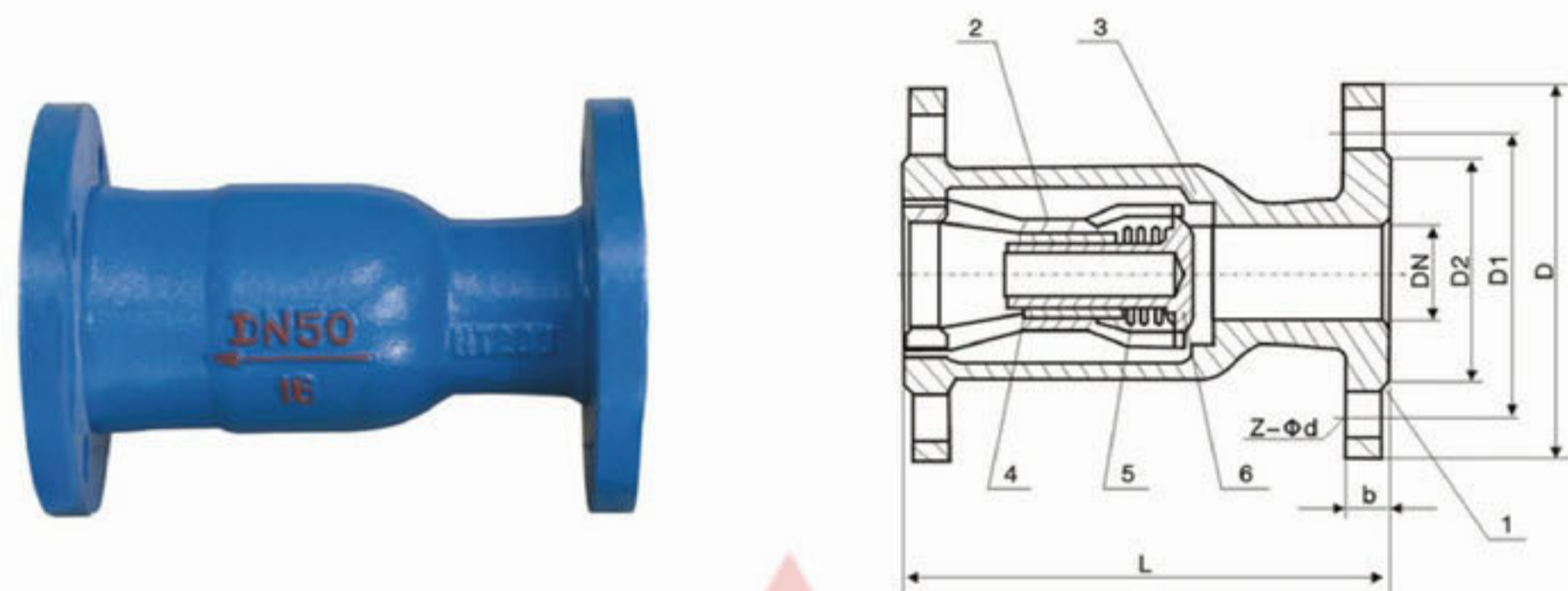

#### 性能规范 Technical Data

产品型号 Type	公称口径 DN(mm) Nominal diameter	性能规范 Technical Data			阀门材质 Valve Material quality		
		公称压力PN(MPa) Nominal Pressure	适用介质 Suitable medium	适用温度(°C) Suitable temperature	阀体 Valve body	阀瓣 Valve clack	密封圈 Sealing washer
H41M-16	15~200	16	水、蒸汽、空气 油品 Water, steam, air and oil	≤250	HT200	1Cr18Ni9Ti	8202
H41M-25	25~200			≤300	WCB		
H41M-25	50~200	25					

#### 主要外形和连接尺寸 Main external and connection dimension

公称口径 DN	L	D	D1	D2	b	Z-φd
15	130	95	65	45	14	4-14
20	150	105	75	55	16	4-14
25	160	115	85	65	16	4-14
32	180	135	100	78	18	4-18
40	200	145	110	85	18	4-18
50	230	160	125	100	20	4-18
65	290	180	145	120	20	4-18
80	310	195	160	135	22	4-18
100	350	215	180	155	24	8-18
125	400	245	210	185	26	8-18
150	480	280	240	210	28	8-23
200	600	335	295	265	30	12-23

### H71型对夹式止回阀

H71 Wafer-type check valves

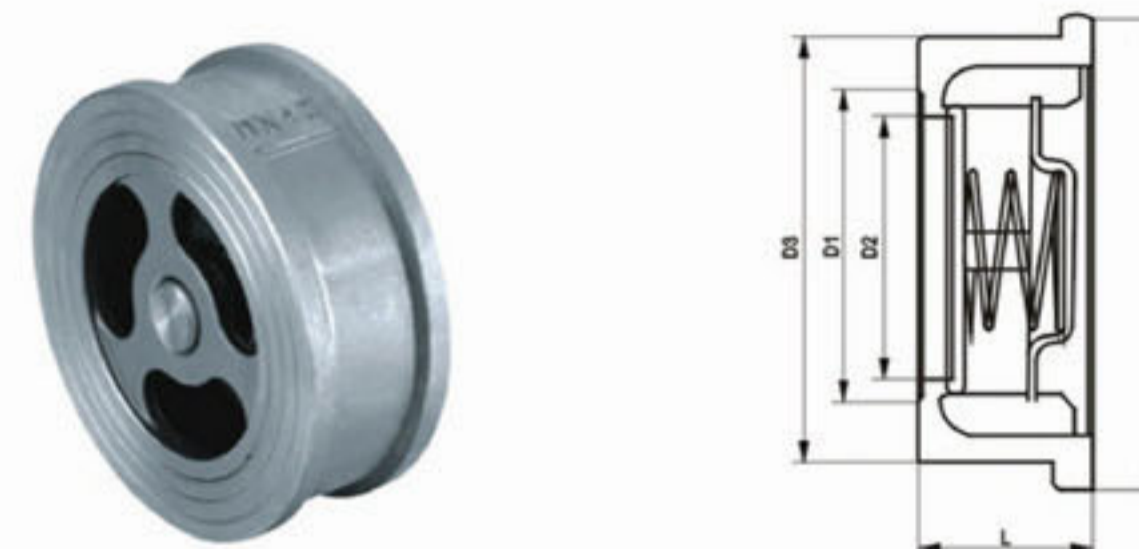

#### H71对夹双瓣旋启式止回阀主要尺寸及重量

公称压力 PN(MPa)	公称口径 DN(mm)	尺寸 (mm)			重量(kg)	配管法兰(供参考)			
		L	D	D2		螺栓孔中 心圆直径D1	螺栓数量	螺栓直径D	螺栓长度L1
1.0 1.6	15	16	53	15	0.12	65	4	M12	75
	20	19	63	19	0.24	75	4	M12	90
	25	22	73	24	0.34	85	4	M12	90
	32	28	84	31	0.53	100	4	M16	100
	40	32	94	39	0.80	110	4	M16	105
	50	40	109	48	1.2	125	4	M16	125
	65	46	129	63	2.2	145	4	M16	130
	80	50	144	78	3.1	160	8	M16	135
	100	60	170	98	5.7	180	8	M16	150
	125	90	198	123	10	210	8	M16	180
	150	106	228	148	14	240	8	M20	210
	200	140	275	198	24	295	8	M20	240
250	160	332	248	35	350	12	M20	260	
2.5	15	16	53	15	0.12	65	4	M12	80
	20	19	63	19	0.24	75	4	M12	90
	25	22	73	24	0.34	85	4	M12	90
	32	28	84	31	0.53	100	4	M16	110
	40	32	94	39	0.80	110	4	M16	115
	50	40	109	48	1.2	125	4	M16	125
	65	46	129	63	2.2	145	8	M16	135
	80	50	144	78	3.1	160	8	M16	145
	100	60	170	98	7.0	190	8	M20	160
	125	90	198	123	12	220	8	M24	205
	150	106	228	148	15	250	8	M24	225
	200	140	284	198	26	310	12	M24	260
250	160	341	248	40	370	12	M27	280	
4.0	15	16	53	15	15	65	4	M12	80
	20	19	63	19	19	75	4	M12	90
	25	22	73	24	24	85	4	M12	90
	32	28	84	31	31	100	4	M16	110
	40	32	94	39	39	110	4	M16	115
	50	40	109	48	48	125	4	M16	125
	65	46	129	63	63	145	8	M16	135
	80	50	144	78	78	160	8	M16	145
	100	60	170	98	98	190	8	M20	160
	125	90	198	123	123	220	8	M24	205
	150	106	228	148	148	250	8	M24	225
	200	140	291	198	248	320	12	M27	275
250	160	353	248	198	385	12	M30	295	



### H74型对夹式止回阀 H74 Wafer-type check valves

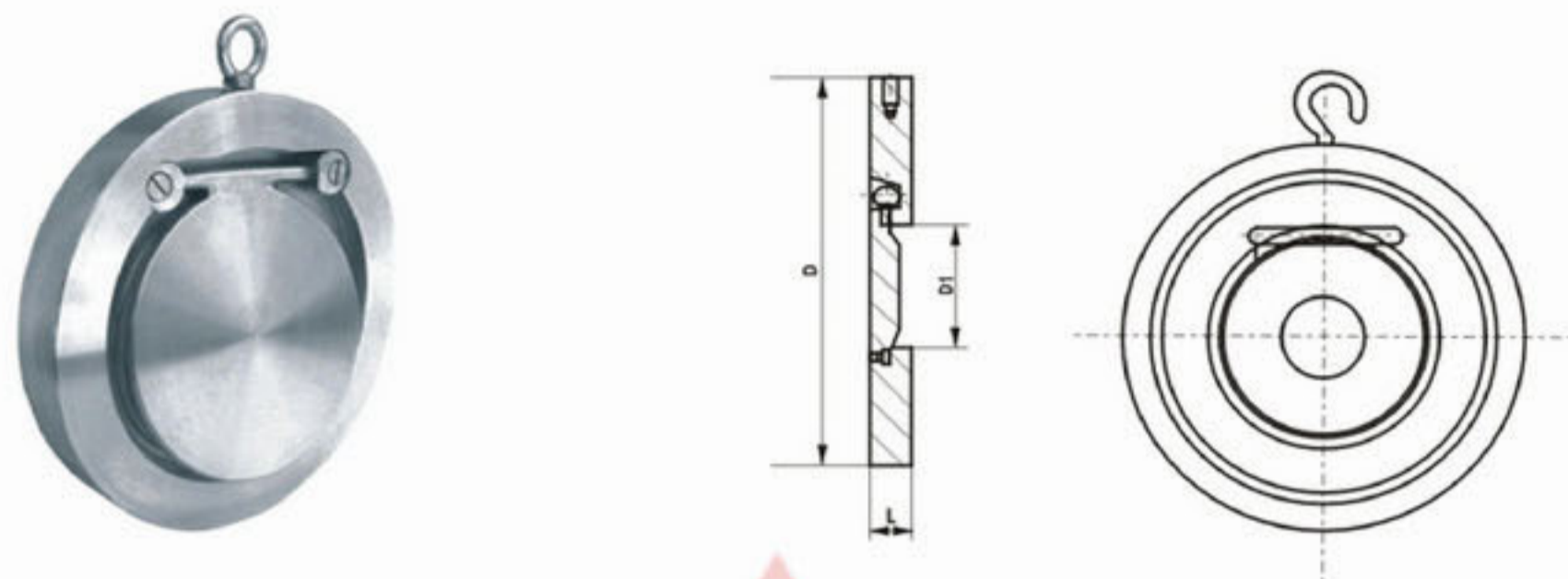

H74对夹单瓣旋启式止回阀主要尺寸及重量

公称压力 PN(MPa)	公称口径 DN(mm)	尺寸(mm)			配管法兰(供参考)		
		L	D	D1	螺栓孔中 心圆直径D1	螺栓数量	螺栓直径D
1.0	50	14.5	109	25	125	4	M16
	60	14.5	129	38	145	4	M16
	80	14.5	144	46	160	8	M16
	100	14.5	164	71.5	180	8	M16
	125	16	194	95	210	8	M16
	150	19	221	114	240	8	M20
	200	29	275	140	295	8	M20
	250	29	330	188	350	12	M20
	300	38	380	216	400	12	M20
	350	41	440	263	460	16	M20
	400	51	492	305	515	16	M24
	450	51	541	356	565	20	M24
500	65	596	406	620	20	M24	
600	70	698	482	725	20	M27	
1.6	50	14.5	109	25	125	4	M16
	60	14.5	129	38	145	4	M16
	80	14.5	144	46	160	8	M16
	100	14.5	164	71.5	180	8	M16
	125	16	194	95	210	8	M16
	150	19	221	114	240	8	M20
	200	29	275	140	295	8	M20
	250	29	331	188	355	12	M24
	300	38	386	216	410	12	M24
	350	41	446	263	470	16	M24
	400	51	498	305	525	16	M27
	450	51	558	356	585	20	M27
500	65	620	406	650	20	M30	
600	70	737	482	770	20	M33	
2.5	50	14.5	109	25	125	4	M16
	60	14.5	129	38	145	4	M16
	80	14.5	144	46	160	8	M16
	100	14.5	170	71.5	190	8	M20
	125	16	196	95	220	8	M24
	150	19	226	114	250	8	M24
	200	29	286	140	310	8	M24
	250	29	343	188	370	12	M27
	300	38	403	216	430	12	M27
	350	41	460	263	490	16	M30
	400	51	517	305	550	16	M33
	450	51	567	356	600	20	M33
500	65	627	406	660	20	M33	
600	70	737	482	770	20	M36	
4.0	50	14.5	109	51	125	4	M16
	60	14.5	129	65	145	4	M16
	80	14.5	144	80	160	8	M16
	100	14.5	170	105	190	8	M20
	125	16	196	127	220	8	M24
	150	19	226	152	250	8	M24
	200	29	293	203	320	8	M27
	250	29	355	254	385	12	M30
	300	38	420	305	405	12	M30
	350	41	477	350	510	16	M33
	400	51	549	400	585	16	M36
	450	51	574	450	610	20	M36
500	65	631	500	670	20	M39	
600	70	750	600	795	20	M45	

### H76型对夹式止回阀 H76 Wafer-type check valves

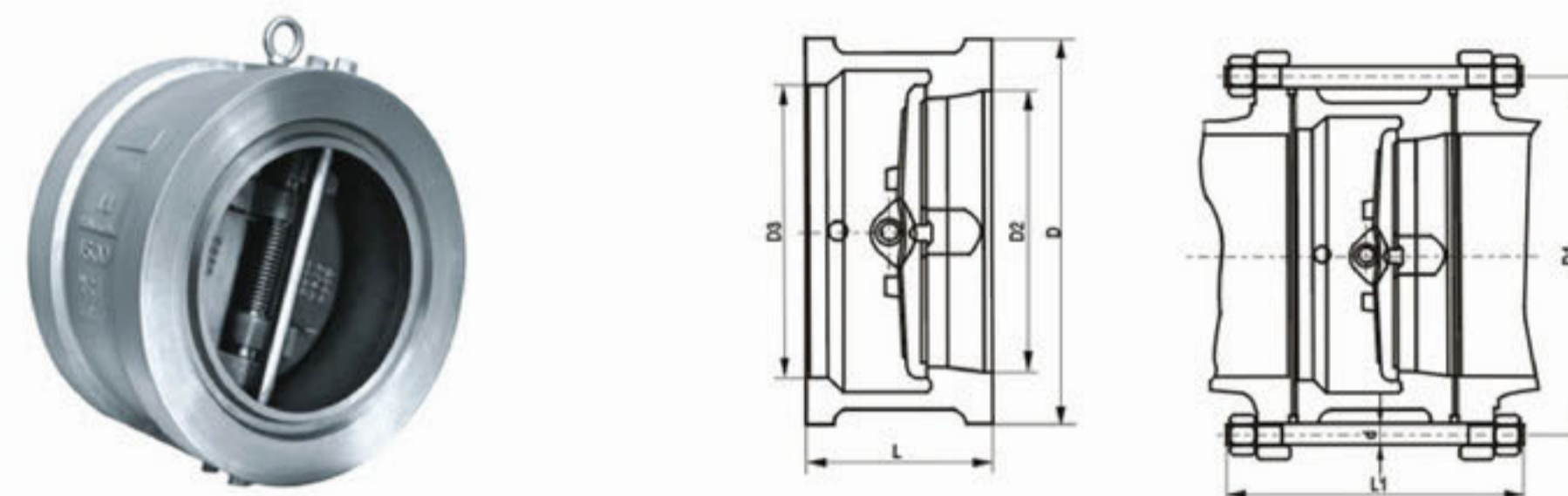

H76对夹双瓣旋启式止回阀主要尺寸及重量

公称压力 PN(MPa)	公称口径 DN(mm)	尺寸(mm)				重量(kg)	配管法兰(供参考)			
		L	D	D3	D2		螺栓孔中 心圆直径D1	螺栓数量	螺栓直径D	螺栓长度L1
1.0	40	60	96	46	41	2	110	4	M16	150
	50	60	109	56	51	2	125	4	M16	150
	65	67	129	73	65	3	145	4	M16	155
	80	73	144	88	80	4	160	8	M16	160
	100	73	164	108	102	6	180	8	M16	165
	125	83	194	132	127	8	210	8	M16	180
	150	98	220	160	152	12	240	8	M20	205
	200	127	275	210	203	24	295	8	M20	235
	250	146	330	266	254	35	350	12	M20	255
	300	181	380	310	305	48	400	12	M20	290
	350	184	440	355	350	78	460	16	M20	295
	400	198	493	405	400	106	515	16	M24	310
450	203	543	455	450	135	565	20	M24	325	
500	219	598	505	500	165	620	20	M24	345	
600	222	698	605	600	260	725	20	M27	355	
700	305	811	700	695	360	840	24	M27	440	
800	305	918	800	796	540	950	24	M30	450	
900	368	1018	903	898	620	1050	28	M30	520	
1000	432	1124	1055	1050	880	1160	28	M33	590	
1200	524	1340	1205	1200	1380	1380	32	M36	695	
1.6	40	60	96	46	41	2	110	4	M16	150
	50	60	109	56	51	2	125	4	M16	150
	65	67	129	73	65	3	145	4	M16	155
	80	73	144	88	80	4	160	8	M16	160
	100	73	164	108	102	6	180	8	M16	165
	125	83	194	132	127	8	210	8	M16	180
	150	98	220	160	152	13	240	8	M20	205
	200	127	275	210	203	24	295	12	M20	235
	250	146	333	266	254	37	355	12	M24	265
	300	181	388	310	305	50	410	12	M24	305
	350	184	448	355	350	80	470	16	M24	310
	400	198	498	405	400	110	525	16	M27	330
450	203	558	455	450	145	585	20	M27	345	
500	219	630	505	500	180	650	20	M30	370	
600	222	734	605	600	280	770	20	M33	380	
700	305	802	700	695	380	840	24	M33	470	
800	305	912	800	796	560	950	24	M36	475	
900	368	1012	903	898	640	1050	28	M36	545	
1000	432	1126	1055	1050	900	1170	28	M39	620	
1200	524	1340	1205	1200	1400	1390	32	M45	735	
2.5	40	60	96	46	41	2	110	4	M16	150
	50	60	109	56	51	2	125	4	M16	150
	65	67	129	73	65	3	145	4	M16	160
	80	73	144	88	80	4	160	8	M16	170
	100	73	170	108	102	6	190	8	M20	180
	125	83	198	132	127	8	220	8	M24	205
	150	98	228	160	152	14	250	8	M24	220
	200	127	288	210	203	270	310	12	M24	255
	250	146	343	266	254	42	370	12	M27	285
	300	181	403	310	305	54	430	12	M27	325
	350	184	460	355	350	86	490	16	M30	340
	400	198	520	405	400	120	550	16	M33	360
450	203	565	455	450	150	600	20	M33	375	
500	219	622	505	500	200	660	20	M33	395	
600	222	732	605	600	340	770	20	M36	410	
700	305	831	700	695	400	875	24	M39	500	
800	305	942	800	796	580	990	24	M45	520	
900	368	1040	903	898	660	1090	28	M45	590	
1000	432	1155	1055	1050	960	1210	28	M52	675	
1200	524	1365	1205	1200	1440	1420	32	M52	790	





## 旋启式内螺纹止回阀 Swing Inside screw Check Valves

### 特点:

全通径流量  
 产品规格从1/4"到2"  
 工作压力:200PSI/600PSI  
 内螺纹端可按BSPT、NPT、DIN2999制造

### Feature

Full Bore  
 Size: 1/4" to 2"  
 Working Pressure: 200PSI/600PSI  
 Female Threaded End: BSPT, NPT, DIN2999

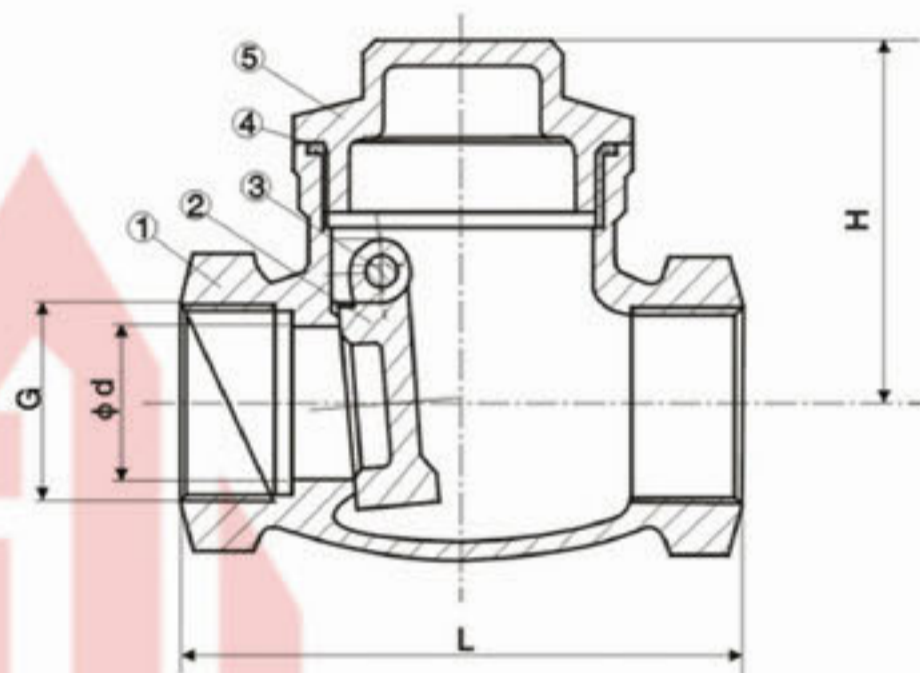

### 材料列表 Materiallist

No	部件名称 Part Name	材料 Material
1	阀体 Body	CF8M
2	阀瓣 Disc	CF8M
3	销轴 Pin	SS304
4	密封圈 Seal Ring	PTFE
5	阀盖 Cap	CF8

### 尺寸列表 Dimension List

单位Unit:mm

NPS	d	L	H
1/4"	6	58	36
3/8"	10	58	36
1/2"	15	66	40
3/4"	20	80	54
1"	25	90	59
1-1/4"	32	105	62.5
1-1/2"	38	120	73
2"	50	140	85

## 立式内螺纹止回阀 Female Inside screw Check Valves

### 性能规范

制造与验收按GB/T12224-1989的规定;  
 其它技术要求按JB 2887-81的规定;  
 供货要求按GB/T12252-1989规定;  
 阀门检查和试验按GB/T13927-92的规定。

### Specifications

Making and confirming according to the regulation of GB/T12224-1989;  
 Other technical requirements, according to the regulation of JB 2887-81;  
 Supply the regulation of demanding to press GB/T12252-1989;  
 The valve is checked and tested according to the regulation of GB/T13927-92.

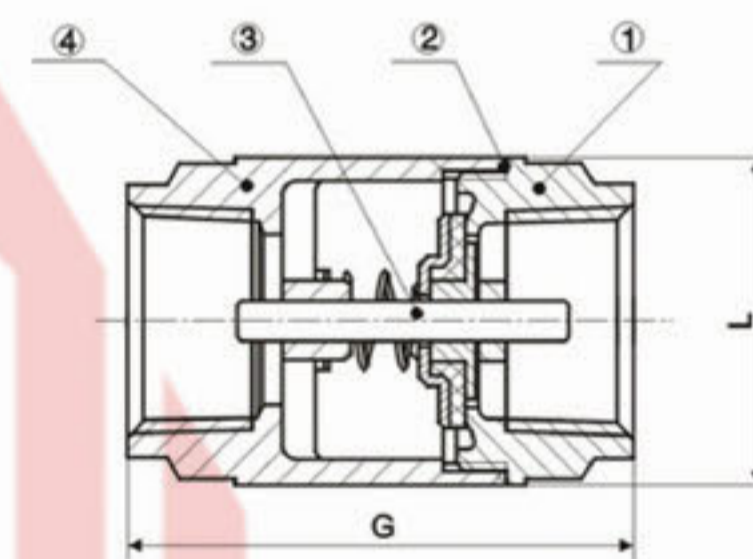

### 材料列表 Materiallist

No	部件名称 Part Name	H14/15F-(16-64)C	H14/15F-(16-64)P	H14/15F-(16-64)R
1	阀体 Body	WCB	ZG1Cr18Ni9Ti CF8	ZG1Cr18Ni12Mo2Ti CF8M
2	阀盖 Bonnet	WCB	ZG1Cr18Ni9Ti CF8	ZG1Cr18Ni12Mo2Ti CF8M
3	阀瓣 Disc	2G1Cr18Ni9Ti CF8	ZG1Cr18Ni9Ti CF8	ZG1Cr18Ni12Mo2Ti CF8M
4	密封 Sealing	304、316、PTFE		
5	填料 Packing	聚四氟乙烯 Polytetrafluorethylene(PTFE)		

### 尺寸列表 Dimension List

单位Unit:mm

G	DN	L
1/2"	15	68
3/4"	20	78
1"	25	89
1-1/4"	32	100
1-1/2"	40	106
2"	50	121